



2025 Specifications, Rules & Regulations

SUPERSTOX

Contents

1. THE FORMULA	2
2. TYPE OF RACE CAR	2
3. VIOLATIONS	2
4. PERSONAL SAFETY	3
5. SAFETY EQUIPMENT	3
5.1 CRASH HELMET	3
5.2 RACING OVERALLS	3
5.3 GLOVES	3
5.4 BALACLAVAS	3
5.5 NECK BRACE	3
5.6 WET WEATHER CLOTHING	4
5.7 HEAD RESTRAINT NET	4
5.8 FIRE EXTINGUISHER	4
5.9 COMPETITION STYLE DRIVERS SEAT WITH HEAD RESTRAINT	4
5.10 SAFETY HARNESS	4
6. VEHICLE WEIGHT & BALLAST	4
7. CHASSIS IRONWORK & ROLL CAGE	4
8. AEROFOIL – ROOF FIN	8
9. FRONT SUSPENSION	8
10. REAR SUSPENSION	9
11. SHOCK ABSORBERS	9
12. WHEEL RIMS	9
13. TYRES	10
14. BRAKES	10
15. ENGINE	11
16. OIL CATCH TANK	12
17. ENGINE SEALING	13
18. INLET MANIFOLD	13
19. CARBURETTOR	13
20. FUEL SYSTEM	14
21. GEARBOX & FINAL DRIVE	15
22. EXHAUST	15
23. COOLING SYSTEM	15
24. THE DISTRIBUTOR & IGNITION SYSTEM	15
25. BATTERIES & ELECTRICAL SYSTEM	16
26. TRANSPONDER	16
27. MIRRORS	16
28. PAINTWORK	16
29. SUN VISOR	16
30. ROOF GRADING	16
31. SPECIFICATION & RULE CHANGES	17
32. RACE RECEIVERS	17
33. DATA LOGGING	17
34. ENGINE RULES FOR SPEDEWORTH 2.0 HOT RODS & SUPERSTOX USING FORD ZETEC ‘Black Top’ 2ltr ENGINE	17

1. THE FORMULA

The object is to complete the specified number of laps in the shortest time. No hitting of parked cars, no four wheels cutting the corners and no deliberate drivers area contact. You may push a car from behind or spin a car left*/right. Attacking a car from or on the infield area is not permitted.

*Spinning a car right and one-on-one follow-ins are not permitted on post and wire tracks.

Actions deemed to be deliberate or dangerous will carry several different types of penalties, this may be being loaded up, a three month ban, banned for a year or even a life time ban.

Additional to the above you cannot follow a car in on the drivers side of the car or hit a car that hard you end up hitting it in the side as it hits the fence, if such action is considered by the meeting steward to not be in within the spirit of the rules/racing to win the offending driver will be subject to a immediate suspension pending a review, to determine whether or not it was done in malice or not. Fencing of a car can only be done by front bumper on the back bumper (As expected in full contact racing).

Racing is in an anti-clockwise direction on a clearly defined circuit with a separate infield.- If all four wheels are over the demarcation line of the infield area the driver will be penalised.

The Malcom Girling Rule may only be used on championship races which covert a roof grade e.g. World Championship. This is when a car has deliberately been taken out by breaking the rules of racing within the last 3 laps of the race e.g. a car coming off the infield to stop the leader / a car giving a 'head-on'.

This does not include a lapped car taking out the leader providing the manoeuvre used is within the permitted rules of racing. If the Steward Of The Meeting decides that the Malcolm Girling has come into effect the result shall go back to when the offence occurred and the leader of the race at that point will become the winner. The Malcolm Girling rule only applies to the driver leading the race.

2. TYPE OF RACE CAR



The Race car must be of an open wheeled chassis design, with a front longitudinally mounted engine, driving the rear wheels. The driver's cockpit must be behind the engine, but in front of the rear axle and be central to the main chassis rails.

All other new cars must have written permission & not verbal permission from Spedeworth before being built. The following companies are sanctioned to be car builders:-

- HCD
- RCE
- WRC

Home built cars can be built as a one off but cannot be a copy of the sanctioned builders specifications.

3. VIOLATIONS

1. When referring to the engine, gearbox, final drive, mechanical or construction Rules & Regulations, the principle will always be: *Unless permission is specifically granted to make modifications (or any variation) nothing may be done to alter or change the Standard Parts in any way.*
2. It is the responsibility of the Driver to prove to the Promotion that the part is legal, by way of written proof of where the part originated. This must be undertaken within 7 days, otherwise the item in question will be

deemed illegal, resulting in immediate suspension from racing & referral for disciplinary action. **Unless the rules say you can do it, you cannot do it!**

3. Presentation of a Vehicle for Scrutineering is a declaration by the entrant that the vehicle is eligible for that event.
4. Car engines & fuel will be checked on a random basis. Violations or refusal to allow an engine check will result in an immediate suspension of all racing facilities.
5. All Car and Engine Specifications will be taken from either the manufacturers Technical Specifications or the Technical Service Data books as published by Glass's Guide.
6. Should a discrepancy occur between the Specifications then the Promotion will exercise its judgement, and that decision will be final.
7. Clarification on any one item may be sought from the Promoter.
8. Each driver is permitted one car per meeting & each car is permitted one driver per meeting.
9. Not to take part, as a person or allow my competition car, my name or racing number to be used with any other promotion without prior permission from Spedeworth.

4. PERSONAL SAFETY

Drivers are advised that under Health & Safety, they are responsible for their own and their Mechanic's actions. Promoters have had complaints made about Registered Drivers & Mechanics consuming large amounts of alcohol at meetings, which could affect their judgement or be detrimental to their health, when medical attention has to be administered by Paramedics, St Johns' or Hospital Staff.

Should an incident occur that proves fatal on the raceway and you are involved, it is likely that the Police will want interview you. **If you drive, don't drink!** Scrutineers and Officials will report to the Clerk of the Course, anybody they believe is under the influence of Drink or Drugs.

Drivers whom it is thought are under the influence may be breathalysed. You have been warned!

Drivers should line up on the grid with their engines switched off in the correct points order, unless told otherwise.

The Flags

This is to remind drivers of the flag signals as used by the Starting Marshall and Safety Marshalls on track.

- Waved Green Flag – Go, the race has started.
- Waved Red Flag – Stop racing slow down & stop.
- Chequered Flag – Race winner has crossed the line, continue to race until the Red Flag is shown.
- Held Yellow Flag – Beware, you are approaching a hazard on the track, continue to race.
- Waved Yellow – Slow down to rolling lap speed, hold your position, and do not overtake any other cars.
- White Flag with a Blue spot – Oil / debris on the track.
- Waved Black Flag - You are disqualified, pull off the track immediately.
- Black cross on a White board – You have committed an infringement and may be penalised in the results.
- White Flag with a Red Cross – Technical Disqualification, leave the track immediately.

Drivers and teams are reminded that a secondary means of supporting a vehicle must be used when working underneath a car that has been jacked up (i.e. axle stands).

5. SAFETY EQUIPMENT

5.1 CRASH HELMET

Please visit the ORCi website www.orci.co.uk for current safety equipment regulations.

5.2 RACING OVERALLS

Please visit the ORCi website www.orci.co.uk for current safety equipment regulations.

5.3 GLOVES

Please visit the ORCi website www.orci.co.uk for current safety equipment regulations.

5.4 BALACLAVAS

Please visit the ORCi website www.orci.co.uk for current safety equipment regulations.

5.5 NECK BRACE

Please visit the ORCi website www.orci.co.uk for current safety equipment regulations.

5.6 WET WEATHER CLOTHING

Please visit the ORCi website www.orci.co.uk for current safety equipment regulations.

5.7 HEAD RESTRAINT NET

Please visit the ORCi website www.orci.co.uk for current safety equipment regulations.

5.8 FIRE EXTINGUISHER

Please visit the ORCi website www.orci.co.uk for current safety equipment regulations.

5.9 COMPETITION STYLE DRIVERS SEAT WITH HEAD RESTRAINT

You must have a Competition type Driving Seat with a head restraint. The seat should occupy its original position where possible and be suitably supported at shoulder height and on both of the sides and back, with a suitable framework or seat stiffener's.

Additional wrap around seat support at shoulder height.

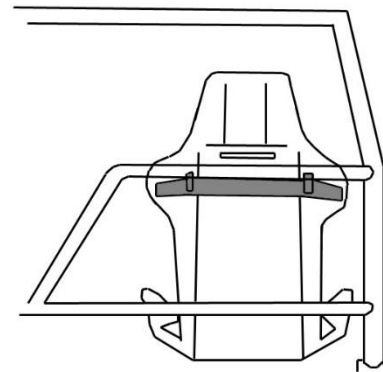

5.10 SAFETY HARNESS

Please visit the ORCi website www.orci.co.uk for current safety equipment regulations.

6. VEHICLE WEIGHT & BALLAST

1. The Race car must not weigh less than 650kg, **Unless using a Zetec Engine then your weight may be down to 640kg.**
2. The Race car must not weigh more than 712kg.
3. Ballast is not permitted & all iron work must be in equal proportions on both sides of the car in both construction & gauge.
4. The left hand side maximum side weight must be 52.50% at any time - this will be weighed without the driver in the car.
5. At no time can any other liquids be added to the Race car to bring it within the weight (should be vehicle weights).
 - a. If you are checked and over the 52.5% but under 53% you will lose all points/monies due on the day and receive a final warning and loaded for the day.
 - b. If you are found on a second occasion to be over 52.5% but under 53% you will receive a one meeting suspension from your registered promotion & cannot race anywhere until this has been served, also lose all points/monies due on the day. Anyone over 53% on their first check will receive an automatic one meeting ban, and loaded immediately with loss of any points or monies due (if applicable).
 - c. If a driver is found over 53% on a second occasion the penalty will automatically be doubled, or possibly carry a longer suspension. Checks will be carried out at any time.

Underweight Vehicle Bans	
Car Underweight by:	Banned From Racing For:
0.001kg – 1.0kg	1 month
1.001kg – 2.0kg	2 months
2.001kg – 3.0kg	3 months
3.001kg & over	6 months

7. CHASSIS IRONWORK & ROLL CAGE.

Key: SHS - Square Hollow Section - CHS – Circular Hollow Section

Chassis

1. The Chassis must be constructed of mild steel with a wall thickness of 3mm. No molychrome or T45 steel to be used anywhere on the Race car.
2. The Chassis must consist of two main chassis rails made from 50x50mm or 2"x2" SHS mild steel.
3. The *maximum* width of the main Chassis rails can be are 737mm or 29" apart.

4. The main Chassis rails must be parallel to each other along the whole length of the Chassis; if they are 29" at the front then they must be 29" at the centre of the rear axle. You cannot off-set or dog-leg the main Chassis.
5. The main Chassis rails when viewed from the side must be positioned above the horizontal centre line, drawn between the front & rear wheel centres.
6. The height of chassis rails must as prescribed, so as to allow the bumpers to be attached to them. NB. Bumper centre height is 432mm or 17" \pm 12.7mm or 1/2", measured at the bumpers centre, without the driver.
7. The Chassis rails must terminate past & above the front & rear axle centres, when viewed from the side.
8. At no point can the main chassis rails drop below the horizontal centre line drawn between the front & rear wheel centres.
9. The Race car must have a welded steel under-chassis, minimum size 25x25x3mm SHS or 25mm CHS, whose wall thickness must be a min 2.5mm & maximum thickness of 3mm.
10. Bracing of the under chassis may be of any thickness or size.

Bumpers

1. Front & Rear bumpers must be fitted & consist of a vertical flat surface 100mm or 4" deep. Ultrasonic thickness testing of the Chassis will also occur, but on a random basis.
2. The bumpers must be no wider than 71" or 1800mm (this includes the wheel guard pick-up points) & no narrower than a centre line drawn through the centre of the tyres.
3. All bumpers must not have jagged edges.
4. Both front & rear bumpers must measure at their centres, 432mm or 17" \pm 12.7mm or 1/2", from the centre of the bumpers flat vertical surface to the ground, without the driver being in the car and as it is presented. The Bumper should be in line with the chassis so therefore we are going to start measuring to the centre line of the chassis height to be 17" \pm 12.7mm or 1/2 ". This is going to be measured in the centre of the lowest parts of the chassis.
5. The bumper may be welded or bolted to the main chassis rails. If welded, it must be on all sides. If bolted, a minimum of four 12mm diameter high tensile bolts & nuts per bumper must be used. NB. The front bumper must also have a secondary fixing of chains one either side (8mm minimum diameter link thickness), with an 8mm "D" Shackles acting as the chain joiners. Bolts with a minimum thickness of 10mm may also be used.
6. The front bumper must have a hoop fitted to the fence side of the bumper which must be between 152mm or 6" & 381mm or 15" measured above the top of the bumper iron. You are allowed a bottom hoop under the bumper.
7. The driver's left-hand rear bumper to the chassis may be strengthened by a piece of 3mm wall thickness tube or box.
8. This rear corner may also have an upright post or hoop added, as per the front bumpers dimensions.
9. Bumpers must be made from 3mm thick mild steel only. The use of 3mm wall thickness tube is permitted but only on the bumper hoops & support.
10. No doubling up of bumpers is permitted - any bumper supports/cross bracing must have a minimum gap of 1 1/2" (38mm) – if there is a gap of less than 1 1/2" (38mm) (due to damage) the final decision on whether the car is permitted to race will be at the scrutineer's discretion.

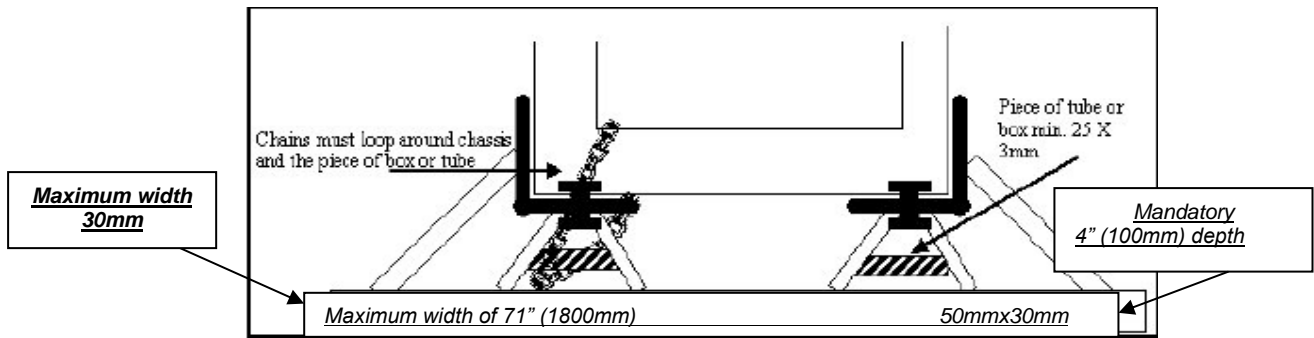

The front bumper should be mounted (welded or bolted) as this is an example in this diagram.

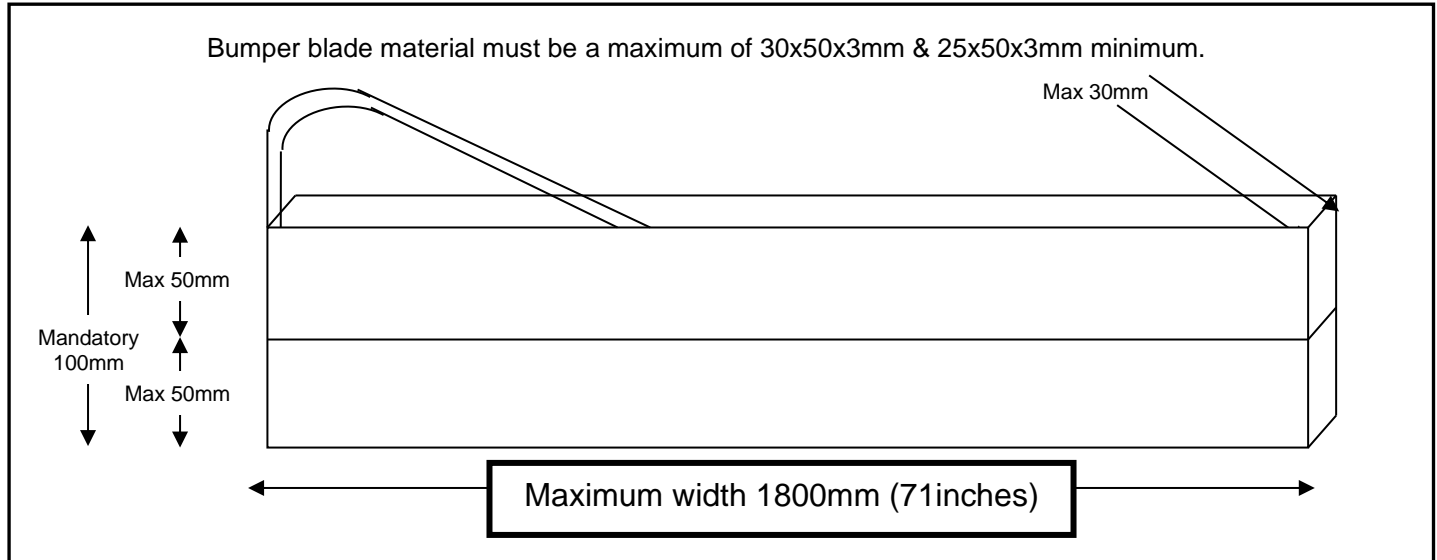

Roll Cage.

The minimum roll cage requirements appear below, but it must be constructed as an integral part of the chassis.

1. The cage minimum requirement is 38x38mm SHS or 38mm CHS, with a wall thickness of 3mm.
2. The front pillars must be raked a minimum of 15° to a maximum of 50°, back from the vertical.
3. Two roll cage hoops, either running from front to rear or side to side.
4. Two roll cage hoop connecting bars.
5. There must be at least a 100mm or 4" of clearance between the drivers head and the roll bars.
6. Gusset plates are optional on all joints.
7. A 3mm thick plate must fill in the top of the roll cage roof & extend to the top edge of the radius of the roll hoop pillar. The plate must be welded on all its sides.
8. Two chicken bars (one each side) must be fitted between the front & rear pillars.
9. The chicken bars must be 304mm or 12" above the main chassis rails or 737mm, 29" from the ground to the top of the chicken bar.
10. The chicken bars must be of a minimum size of 25x25x3mm, 32x32x2.5mm or 38x38x2.5mm and made from box or tube. These chicken bars should have a minimum of two down connecting bars also made from tube or box using either 25x25x3mm, 32x32x2.5mm or 38x38x2.5mm.

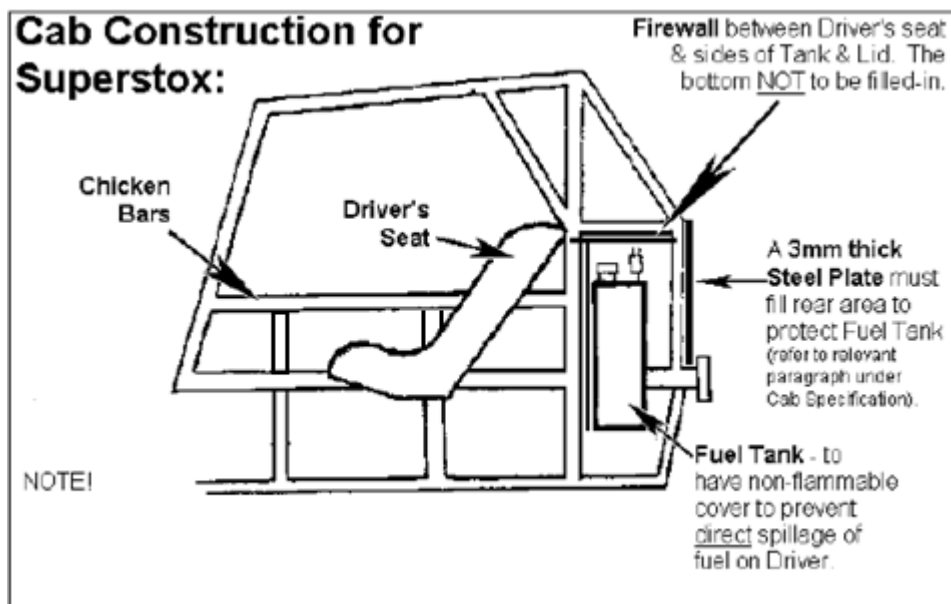

Cab Specifications.

19. The Cab must be at least 711mm or 28" wide between the chicken bars at the driver's seat.
20. The *minimum* size of the Cab side openings is 457mm or 18" in width by 406mm or 16" in height.
21. The Cab floor must be completely filled in up to the seat with metal. *See also point 7.*
22. If the Cab floor is below the chassis, the sides must be filled in & braced to prevent the driver's legs or feet going outside or the Cab.
23. A metal firewall must exist between the front of the Cab & the Engine Bay.
24. A metal fire wall must exist between the rear of the seat and the fuel tank, including the filler cap. *See diagram.* NB. The bottom of the tank must be left open for spillage purposes.
25. A 3mm plate must be welded directly behind the fuel tank to protect it from rear impact damage. The plate must be welded on all four sides & be a *minimum* of 304mm or 12" high, above the main chassis rails.
26. The driver's seat must be of a competition type with suitable side supports and a headrest. The seat base must not be less than 305mm or 12" from ground level.
27. The back of the seat/headrest must be at least 254mm or 10" from the rear of the Cab. NB. The rear of the Cab being a vertical line from where the roll cage hoop meets the main chassis rails.
28. The seat must be securely fitted to the centre of the chassis and not leaning side to side & attached to the roll cage at shoulder height.
29. A steel plate, of a 3mm thickness must be fitted below the seat & welded to the chassis or bolted to the seat. It must be the full width of the seat base & a minimum of 203mm or 8" in length. The purpose of the plate is to protect the driver's posterior from the prop-shaft, should it break!
30. Any part of the prop-shaft not covered by the seat plate must be covered by a suitable metal covering.
31. A steel hoop must be fitted around the prop-shaft to catch it in the event of either end of the prop-shaft breaking.
32. The only part of the underside of the Race car that may be covered in metal is the area between the firewall & the front of the driver's seat, to a width of the main chassis rails.
33. A sump guard may be fitted – maximum thickness 3mm.
34. You may run a tape or mesh net shield in the driver's side windscreen aperture for inclement conditions, this can be removable and fixed with ties or tape only or if permanently fixed must be welded. This is mainly for wet meetings.

Side Irons

1. These must be constructed of a minimum 25mm or (1") 3mm thick mild steel in either tube, box or channel section & be of equal proportion in construction on both sides of the Race car.
2. The side irons must be level with the outside edge of the tyres \pm 38mm.
3. The side irons must be Minimum 100mm or 4" in depth & run horizontally at bumper height between the front & rear wheels with a minimum return at front end of 50mm or 2". But must be symmetrical side to side
4. A *minimum* of two supports with a 3mm wall thickness is allowed from off of the main chassis to the side irons. Any other supports may be of any size or gauge.
5. The side irons must not terminate more than 203mm or 8" from the tyres outer circumference.

6. The style or shape of the side irons is free but must be symmetrical (with a maximum of 2" (50mm) difference from side to side).
7. The maximum of the car/side irons at any point is 71" (excluding spring guard).

Rear Wheel Guards

1. Both rear wheels must be fitted with guards so as to prevent the wheel becoming detached from the hub.
2. A piece of spring steel is the ideal material, and it must be mounted so that the front facing section of the leaf is located inside of the side iron and the rear of the leaf is attached to the rear bumper. See diagram.
3. Cold bending of the spring is only permitted method, no heating or welding is permitted, otherwise it will upset the temper or the material.
4. High tensile fixing bolts must be used either end with a *minimum* diameter of 12mm.

8. AEROFOIL - ROOF FIN

An aerofoil is defined as one wing & two side fins. No other aerodynamic aids are permitted anywhere on the Race car.

1. A single fin plate mounted centrally on the roof with the racing number on it is permitted.
2. Two fin plates positioned either side of the roof with the racing number on them is permitted.
3. Fin plate numbers must be 229mm or 9" high by 38mm or 1½" in width, plain black numbers on a plain white background only. Please ensure they are correct. No Holographic numbers or background
4. An aerofoil made from aluminium or fibreglass can also be used, but its maximum dimensions must not exceed 1219mm or 48" in breadth and 457mm or 18" in depth.
5. Side fin plates must be located horizontally on the aerofoil & be identical in position.
6. The maximum size of the fin plates is 660mm or 26" in width by 305mm or 12" in height.
7. The side fins must not cover any part of the side window aperture
8. The aerofoil must be mounted centrally on the roof so that any overhang is in proportion, either side of the roof.
9. The aerofoil front edge must not be any further forward than the front edge of the rear tyre.
10. The aerofoils front edge must not be positioned any further back than 914mm or 36" from the tyres front edge.
11. The aerofoil can use steel brackets to mount it, but it must not be mounted any higher than 305mm or 12" above the roof.
12. The aerofoil must be positioned horizontally on the roof & not look lopsided.
13. **Any** part of the wing or fin plates must **not** obstruct the driver's entrance or exit **from the car**.

9. FRONT SUSPENSION

1. Any type of suspension is allowed, wishbones, track control arms, compression strut arms and stub axles/front hubs must be made of steel. No T45 OR Crome Moly is to be used.
 2. **The only parts for suspension which maybe aluminium are as follows, Rockers, Drop Arm, Sliders (Suspension Arm Sliders), Steering Rack Extensions, Steering Rack Holding Mounts and Rose Joints. Any other part of the suspension is not permitted to be aluminium.**
 3. Suspension may be offset.
 4. The maximum front track width, which is measured on the centre line of the front axle, at the lower outer edge of the tyre is 1727mm or 68".
 5. No anti-roll bar is permitted. No torsion arms or any connecting arms from one side to the other on the suspension.
 6. In-board suspension will be symmetrical from side to side with the same rocker ratio.
- Front Hubs & Stub Axels**
7. It is *not* permitted to use any stub axle with a fixed bearing spindle, as is the Cortina, unless approval is sought. A Cortina type replacement, available from Randall Motorsport, has been approved for use.
 8. Any Modified hub, production, or purpose built hub, or stub axle (not including the Cortina) is permitted, but it must be made of steel and it can only use a steel wheel rim to a maximum width of 5½ J.
 9. Both front hubs must be *identical* (i.e. whatever is on the NSF must be a mirror image on the OSF).
 10. Any front suspension must be symmetrical to the chassis rails, with the following tolerance for positive or negative camber.
 - 9.a TOP: from centre of the chassis rails to the centre of the top joint, ± 25mm (1)

9.b BOTTOM: from the centre of the chassis rails to the centre of the bottom joint, $\pm 38\text{mm}$ (1 1/2")

9.c You may have equal length suspension arms and move the mounting points by 25mm (1") at the top & 38mm (1 1/2") at the bottom or have unequal length suspension arms and keep the pickup points symmetrical to chassis.

Wheel studs must be level with the wheel nut or protruding slightly through. It will be the scrutineers' discretion as to whether the studs are protruding through too far and you may be asked to cut them flush.

The wishbones and the front / rear track, may be checked by the Scrutineers at anytime.

10. REAR SUSPENSION

1. The only rear axle permitted is the Ford unit as fitted to the Cortina, Capri or Escort.
2. The half-shafts must be the semi-floating bearing type as fitted to the axle, in their original position & with the bearing retaining collars welded. 2-piece competition half-shafts may be used.
3. On the occasion that a bent axle tube is replaced, a slightly larger diameter axle tube may be used to sleeve – minimum thickness 2.5mm.
4. The axle casing must not be modified in any way to achieve Camber change or rear steer.
5. All axle link bars must be made out of mild steel tube or box, not aluminium **No T45 OR Cromex Moly is to be used.**
6. **The only parts for suspension which maybe aluminium are as follows, Rockers, Drop Arm, Sliders (Suspension Arm Sliders), Steering Rack Extensions, Steering Rack Holding Mounts and Rose Joints. Any other part of the suspension is not permitted to be aluminium.**
7. Any type of fixed adapter or spacer fitted to the hubs, shafts or wheels is not permitted.
8. Any type of spacer to alter the rear track is not allowed.
9. The maximum rear track width, which is measured on the centre line of the rear axle, at the lower outer edge of the tyre, is 1727mm or 68".
10. Differentials may be locked by welding or remain un-locked.
11. Axle must be fitted centrally to the chassis rail, measured from the centre of the axle casing $\pm 25\text{mm}$ (1")
12. No anti-roll bar is permitted. No torsion arms or any connecting arms from one side to the other on the suspension.
13. In-board suspension must be symmetrical from side to side with the same rocker ratio.

Wheel studs must be level with the wheel nut or protruding slightly through. It will be the scrutineers' discretion as to whether the studs are protruding through too far and you may be asked to cut them flush.

All fasteners nuts & bolts used to retain the major components i.e. front and rear suspension, steering gear, engine and transmission, seat, pedals, fuel and oil tanks, radiator and batteries must be mild steel only.

All nuts and bolts are not permitted to be lightened or drilled but maybe cut down flush to the nut.

11. SHOCKER ABSORBERS

1. **Each corner of the car is only allowed one shock-absorber.**
2. **All 4 shockers must be the controlled Gaz/Spedeworth steel shocker.**
3. **These shockers cannot be modified in anyway apart from the top eyelet can be replaced with a longer top eye.**
4. **These can be purchased from Spedeworth Fabrications on 01252 322934.**
5. **A spring tether must be fixed around the spring and attached to the chassis, to both front and rear springs. The spring tether must be a BSCDA approved item and can be purchased from the BSCDA trailer at race events or from Spedeworth Motorsport, DMC or HRP race events. Each tether costs £5.00. This rule is in effect from 1st February 2025.**

12. WHEEL RIMS

1. The wheel rims must be made of Steel only, No alloys are allowed.
2. The wheel off-set must be equal on the same axle, but they can be different on the axle's front to rear.

3. The maximum rim width on the rear is 8”.
4. Front Modified hubs (see above for definition, it includes the Sierra hub) can only have a rim width to a maximum of 5½ J.
5. Front un-modified Sierra hubs can be up to a maximum of 8”.
6. Wheel studs must be level with the wheel nut or protruding slightly through. It will be the scrutineers’ discretion as to whether the studs are protruding through too far and you may be asked to cut them flush.

13. TYRES

1. Only the Hoosier HSPRT 24.0 x 6.0 x 13 tyres can be used.
2. Tyre side wall identification marks must not be removed.
3. Tyre softener **or any tyre contamination** is not permitted. **Tyres will be randomly durometer checked.**
4. Tyre cutting is not permitted.

Tyre Ruling: **One new tyre is permitted at every other domestic meeting that a driver races** e.g. visiting drivers can class that event which would be non-points scoring as their second (other) meeting, this tyre can be banked but must be logged along with any 5 old tyres that have been previously used and declared (except at Eastbourne where you may use more old tyres if not using a new one). These used tyres MUST appear in the drivers tyre history. The new tyre maybe banked if registered.

Championship meetings sit outside this ruling, and will always have their own separate allocation and will not affect your own domestic meeting tyre cycle. These meetings are: World, European, British, National, Inter-Nations Cup, Best in Britain, English, Scottish, Irish.

Drivers MUST book-in for ‘away’ meetings with their home promoter to allow the away meeting to count towards the tyre allocation rule.

At the following championship events:-

- World, you are allowed a maximum of 6 tyres of which **4** can be new the other **two** must be registered previously..
- European / National / British, you are allowed a maximum of 6 tyres of which **2** can be new, the **other four** remaining tyres must be used registered tyres.
- Best In Britain / English / Scottish / Irish, you are allowed a maximum of 6 tyres of which 1 can be new, the five remaining tyres must be used registered tyres.

The scrutineers discretion will determine if a tyre is classed as a used tyre.

New drivers may use 4 new tyres for their first meeting but must start at the rear of the grid for their first 3 meetings and not have another new tyre until their 4th meeting.

If you have declared the wrong tyre number you will be loaded for this meeting and all points removed as well & will also result in a 1 meeting ban.

Tyre sharing is not permitted unless the tyre has been declared and used at 3 meetings. You must also declare this with the office before the meeting.

All drivers must register on the drivers tyre website- www.superstox-drivers.co.uk. This website must be used by all drivers to log tyres from every meeting that they attend. They have 2 days from the day of the meeting to upload their tyre log from the attended meeting. Drivers who fail to upload their tyre logs to the Superstox Tyre Log website will be allowed the maximum of one failure of doing so. On the second failure the penalty of not being permitted a new tyre at the next meeting the driver should be eligible to have a new tyre at will be forfeit. The website can be used by all drivers to view or search a history of a specific tyre, and the facility should be used to ensure a previously used tyre has done the adequate number of meetings before another driver can log it as USED, Where tyres have been bought from another driver this information should be left in comments box the first time you submit the tyre on the website. Tyre logs must still be handed into the scrutineer on the day, and this must match the log submitted online. Where the event is a 2 day event, the 2 days will start at the end of the weekend (IE from the Sunday on a Saturday/Sunday Event).

14. BRAKES

Brakes must be effective on all four wheels.

1. **Callipers.** No aluminium or four pot callipers are permitted. Callipers must be symmetrical from side to side on the same axel including piston size. No grinding or drilling is permitted.
2. **DISCS.** Only steel discs are permitted to a maximum diameter size of 240mm. Drilling and grooving of the discs is permitted, but the discs must be symmetrical IE – what is done to one side must be the same the other side on the front or back.

3. **Brake cylinder.** You will only be allowed to use a single brake cylinder which will work front and back brakes.
4. **Brake Reducer.** You are only allowed one brake reducer in the brake line which will be to reduce the back brakes. This must be on show in the drivers compartment where it is visible. Any other restriction in the brake lines or in the brakes will be deemed as illegal.
5. **Brake Pads.** Brake pads are free, but no modifications are permitted.
 - Left foot braking is optional.
 - Brake Pressure must be the same side to side, for example inside front wheel must be the same as the outside front wheel & the inside rear must be the same as the outside **rear wheel**.

15. ENGINE

The engine must be fitted between the two parallel chassis rails whereby the carburettor / inlet manifold, must not protrude past the outer edge of the chassis rail.

Block / Crankcase

1. The only engine permitted is the Ford 2 litre SOHC Pinto, whose bore is 90.84 mm & stroke is 77mm. We have now added the ford zetec black top engine aswell, see the end of the rule book for more information on this engine.
2. The block maybe re-bored to a maximum of 1.5mm.
3. Sleeving back to 90.84mm is permitted, as well as re-boring the sleeve, to the maximum of 1.5mm oversize.
4. The bore size racing tolerance of 0.005" is permitted, when in-line measured with the crank.
5. The Cylinder block maybe decked, but the pistons must not protrude above the blocks face.
6. Core plugs maybe secured with a secondary fixing.
7. The outside surface of the engine may be painted.
8. Standard Ford, Payne & including the standard American Gaskets, are the only ones to be used anywhere on the engine.
9. No competition gaskets are allowed on the engine or ancillaries.

Pistons

1. Pistons must be standard or standard replacements e.g. Schmidt, Mahle, Hepolite, Wellworthy & Associated Engineering (Federal Mogul).
2. Piston crowns must not be skimmed & markings must remain on the crown for identification purposes.
3. Pistons must not protrude above the block face.
4. Three Pistons may be balanced by spot machining, the fourth piston must be original & untouched.
5. Pistons and or Gudgeon pins must not be modified in anyway, apart from the spot machining of the piston.
6. Any make of Piston Ring may be used, providing there is no machining of the pistons or rings.

Connecting Rods

1. No forged steel rods are allowed.
2. Three Con-rods may be spot machined on their counter weight balance pad area, at the big & small ends, but the fourth rod must remain original and untouched.
Con-rod bolts may be changed but the rods must not be modified in any way to accept them

Crankshafts

1. The standard Crank must be used.
2. Cross-drilled shafts are not permitted.
3. Oil way holes on each journal can be relieved.
4. You cannot alter the number of bearings, or fit bearings of less than the minimum width.
5. Over-size shell bearings of standard or heavy duty materials are allowed.
6. Tufriding & Nitriding of the shaft is permitted, but polishing is not.
7. No forged steel cranks are permitted
8. Cranks may be balanced, but by spot machining only. N.B. Spot machining means either, hand grind, drill or machine.

The Standard pulleys on the crank & auxiliary shaft must be used. Replacement of standard crankshaft pulley with machined manufactured pulley is permitted. The circumference of any replacement crankshaft

pulley must remove at least a minimum of 363mm, this equates to a minimum diameter of at least 115.55mm. The weight of any replacement crankshaft pulley must measure at least a minimum of 600g.

Flywheel

1. Only the 2 litre flywheel can be used.
2. Flywheels must be dowelled to the crankshaft.
3. The 2 litre flywheel may be lightened, NO HOLES or SLOTS its minimum weight is 12.7kg, this includes the clutch assembly, dowels & bolts.
4. The Flywheel and clutch assembly may be balanced by spot machining only.
5. No competition clutches are allowed.

Cylinder Head

1. Any 2 litre casting is allowed
2. The head face may be skimmed.
3. Material must not be added or removed from the ports or combustion chamber, it should remain as standard.
4. Valve guides may be fitted but they must be the Ford replacement type, but not the bronze or competition types.
5. The use of thin wall bronze inserts in existing guides is permitted.
6. Inlet Valves must be standard; their length must be 110.65 – 111.65mm. with a head diameter of 42mm. N.B On standard Ford Inlet Valves only, where the back of the valve meets the valve seat, there may be a slight lip, this may be ground away at a 30° angle, to a maximum width of 2.5mm.
7. Exhaust Valves must be standard; their length must be 110.10 – 112.05mm. with a head diameter of 36mm.
8. Any single or double valve springs may be used, and the head may be modified to allow them to fit Including Shimming.
9. You may use standard Ford Pinto or steel spring tops.
10. You may replace the ball studs for a complete set of the extended type.
11. When valve seat inserts have been fitted, the lower edge of the insert, where it meets the throat of the port, can have this sharp edge only blended in.
12. Three angle valve seats are permitted.
13. The centre camshaft cap maybe re-enforced. Camshaft pillars – one must remain standard/unmodified – a maximum of two may be welded/repared.

Camshafts

1. Camshafts are free & may also be of the centre drilled type.
2. The spray bar may be removed & a splash shield may be fitted.
3. An adjustable type cam wheel or off-set keys are allowed.
4. The standard length 2 litre cam belt & its tensioner must be used, which must not be modified in any way.
5. Roller cam bearing are not allowed.
6. Rocker arms are free, but no roller rockers are allowed.
7. Rocker arms may have the ends nipped.
8. Heavy duty rocker finger retaining springs are allowed.

Lubrication System

1. A high pressure oil pump may be used but not be a high capacity type pump.
2. Dry or semi-dry sumps are not allowed.
3. Oil galleries in the block & head must remain un-modified.
4. The oil pick-up pipe must terminate within the sump.
5. Sumps may be modified to hold more or less oil & may be baffled to prevent surge.
6. The oil filter must have a secondary fixing & the filter must occupy its original position.
7. Oil coolers may be fitted in the engine compartment only, using the sandwich plate between the filter & the block.

16. OIL CATCH TANK

1. A 0.5 litre oil catch tank (no drink cans or bottles) must be fitted in the engine bay.
2. The tank may have a minimum of 2 breather pipes connected to it: one from the rocker box & one from the crankcase.
3. Ineffective tanks during racing or practice will mean the car being withdrawn from the event.

17. ENGINE SEALING

Spedeworth: We may at any time require your engine or other parts to be sealed. This may or may not mean your engine / parts will automatically be stripped or checked. It could be that we wish to monitor your performance or seek clarification on an item. It is normal to strip engines at all major championships unless they run consecutively in which case by agreement with Spedeworth, stripping may be postponed.

Driver: Drivers wishing to have their engines sealed may do so. It will require two people (one may be an official, the other a Scrutineer) to be present at the final stages of a build & it will incur a charge based on the time & distance travelled. If this option is taken at a major championship; your engine will not require stripping, unless seals have been broken. Seals can only be removed by Spedeworth officials & if they are removed without permission the engine / parts will be deemed to be illegal & the Driver suspended pending a Board of Control meeting. If any engine/ parts are sealed because Championship events are within a period, which may exclude that Driver due to a rebuild, the Driver with Spedeworth's agreement, postpone stripping for three meetings.

It is the Drivers responsibility to make provision for the sealing of the engine by drilling 1.5mm sealing holes in the following bolts / nuts & marked them with red paint for identification purposes:

- Either side of the Sump
- Two Head bolts, if not covered wholly by a rocker / cam cover.
- Two Inlet manifold bolts
- Two Rocker / Cam cover bolts
- The Bell housing
- The Carburettor body and its mounting bolts / nuts

18. INLET MANIFOLD

1. Must remain as standard, the faces cannot be faced to alter the angle of the manifold or the carburettor.
2. No inlet port matching from the Carburettor flanged face will be permitted or from the manifold ports to the head.
3. No material may be added or removed from the gas-flow area.
4. Water holes may be blanked off.
5. A stabiliser bar may be fitted to support the manifold.

19. CARBURETTOR

1. Only the Weber n32/36 DGV or DGVA carburettor may be used with a maximum sized chokes of 26mm and 27mm.
2. No polishing or re-profiling is allowed.
3. No modifications to the carburettor body or the original design.
4. Gaskets must be the original or pattern replacement, with no modifications made to them
5. The Insulation block & two gaskets must be fitted between the carburettor and manifold.
Max thickness 5mm.
6. All jets, emulsion tubes and Venturi's may be replaced with different ones of the same type.
7. Accelerator pump jets may be changed, but the outlet of spray beak must face down towards the throttle butterflies.
8. Throttles may be modified to open together
9. Cold starting devices may be removed & the holes blanked off.
10. Air & fuel galleries may not be enlarged or modified.
11. Floats may not be modified or weighted and must control fuel flow.
12. Float chamber needle valves may not be modified or be larger than 250.
13. The calibrated brass bush which controls the high speed enrichment, fitted on the Secondary choke side of the carburettor between the top and the carburettor base, *may be modified*.
14. The power valve in the base of the float chamber may be sealed off & the diaphragm removed.
15. A grub screw or similar device may be used to secure the auxiliary venturi to the carburettor body.
16. A secondary fixing is required on the fuel feed to the carburettor.
17. Sealing wire holes must be drilled in the appropriate places.
18. No trumpets are allowed.
19. The interchanging of the carburettor top from other Weber models is not allowed.

20. FUEL SYSTEM

1. All fuel tanks must be made of metal & have a positive means of fixing.
2. The tank must be mounted behind the driver, between the chassis rails and have a maximum capacity of 18 litres.
3. Fuel tank caps must be of the metal screw on type, no push fit caps are allowed.
4. The fuel tank & cap must be covered by a complete metal fire wall.
5. The fuel outlet must be from the top of the tank.
6. A breather pipe; which incorporate a one-way valve, must be fitted
7. All fuel pipes must be inside the race car.
8. If a floor exists under the tank, there must be four 50mm drain holes in case of spillage. It is advised that the bottom area of the tank be left open.
9. A fuel shut off tap must be within easy reach of the driver.
10. A single electric pump may replace a mechanical one.
11. Fuel regulators are permitted.

All Oval Racing Formulae

Permitted fuel specification from 1st January 2008 (this specification supersedes all previous specs).

1. All cars must only use fuel from roadside pumps as defined below.
Petrol, (Motor Gasoline of the type on sale to the general public from roadside filling stations), BS 4040 (Leaded). Subject to a valid permit for use, LRG (Unleaded), BS EN 228 (Unleaded), BS7800 (Super Unleaded).
2. Petrol is a product refined from crude oil that contains a large number of identifiable compounds that can typically be 250 in number. These compounds can be identified and compared to the available petrol from major oil companies and suppliers.
Unless otherwise stated, or the distinction is made between leaded and unleaded petrol, major gasoline fuel shall meet the following; Acceptance levels for Octane numbers will be determined at 95% confidence level. Only additives to this motor gasoline fuel solely for the purpose of lead replacement are allowed.
3. Lead Replacement Gasoline, LRG, also known as LRP. Only additives from Sodium, Phosphorous, Potassium, or Manganese according to manufacturer's recommendations are allowed. Note; Manganese can enhance octane values in any petrol. Under no circumstances will values in excess of 0.005 grams/litre be permitted.
Lead in excess of EU directive 98/70EC requirements is illegal.
5. We reserve the right to amend the detail of the above specification to reflect any change occurring in the quality of the fuel on sale to the general public at any time.

Roadside fuel consistency when testing fuel samples

	BS EN 228	BS 7800	BS 4040	LRG/LRP	Test Standard
Motor Oct No (max)	89.0	89.0	89.0	89.0	ASTM D2700/86
Mon (min)	85.0	86.0	86.0	86.0	ASTM D2700/86
Research Oct No (max)	100.0	100.0	100.0	100.0	ASTM D2699/86
Ron (min)	95.0	97.0	97.0	97.0	ASTM D2699/86
Lead (max)	0.005	0.005	0.15		ASTM D3341 / IP362
Lead (min)	ASTM D3237	ASTM D3237		0.005	ASTM D3237 / D3341 / IP362
Density @ 15°	0.720 - 0.775	0.720 - 0.775	0.720 - 0.775	0.720 - 0.775	ASTM D1298/ D4052
Oxygen % max	2.7% w/w	2.7% w/w	2.7% w/w	2.7% w/w	Elemental
Nitrogen % max	0.1% w/w	0.1% w/w	0.1% w/w	0.1% w/w	ASTM D4629/ IP379
Benzene % max	1.0% v/v	1.0% v/v	1.0% v/v	1.0% v/v	EN238
Sulphur	150mg/kg	150mg/kg	150mg/kg	150mg/kg	EN ISO 14596 / ASTM D2622
Olefins*	18% v/v	18% v/v	18% v/v	18% v/v	ASTM D1319
Aromatics*	42% v/v	42% v/v	42% v/v	42% v/v	ASTM D1319

* Olefins and Aromatics values are expressed as a percentage of total fuel.

21. GEARBOX / FINAL DRIVE

1. **The only gear boxes permitted for use are the single rail, 2.0 Litre Cortina type 4 or the 5 Speed Sierra Gearbox The 2nd Gear Must be 1.97. It must be fitted as manufactured.**
2. Gears must not be changed or altered, i.e. no removal of gears or components, and no straight cut or close ratio gear sets. No polishing of gears.
3. The only exception is that the gear change assembly may be altered; this may include part of the tail-shaft housing associated with the gear change only. Aluminium bell housings are permitted & you may enlarge the existing hole in order to give excess to the clutch cable/Fork. A clutch is required and must be operated by a pivot arm from the outside of the bell housing.

Differentials:

Differentials may be free or locked only; the use of limited slip, power lock, torque twist, torque bias, or any type of competition diff, is not allowed. No polishing of crown wheels or pinions is permitted.

There is no mixing and matching of crown wheel and pinions. No competition ratios. For example, if you are running a front-loading Ford axle your ratios should be either a 4.4, 4.1, 3.9, 3.89, 3.7 or a 3.5

If you are running a Cortina axle then you should be on Cortina ratios.

22. EXHAUST

1. Exhaust manifolds are free, but they must be positioned outside the main chassis rails on the offside of the car.
2. A silencer must be fitted outside of the main chassis of the car.
3. The silencer as well as reducing noise must have the original pipe work protruding from each end of the box
4. The length of the silencer tail pipe, from the end of the box to the end of the tail pipe, has a maximum length of 75mm or 3"
5. The silencer must be of the following type: A Simpson MS500 or **Edwards Motorsport.**
6. The exhaust system, including the box must not exceed £444 plus VAT for the straight-type exhaust and £504 plus VAT for the dropdown-type exhaust & be freely available to anyone. The exhaust system must stay on the right-hand side of the car using a pinto engine and on the left-hand side of the car using a zetec engine.
7. Where the exhaust passes the cockpit or cab, the exhaust system must be covered with a metal heat shield.
8. 4 into 2 into 1 exhausts are not permitted for use.
9. Zetec's are permitted to run a 4 into 1 four branch manifold.
10. **You may polish the exhaust system on the outside if you wish.**
11. **No ceramic coating or any other coating is allowed except heat wrap.**

23. COOLING SYSTEM

1. Radiators are free,
2. The radiator must be positioned in front of the engine inside the chassis rails. The radiator must be covered by an ally cover if located outside of the bonnet.
3. The water flow circuit must terminate forward of the drivers cab.

Crankshaft / water pump drive belt is free but water pump must remain standard. Replacement of standard crankshaft pulley with machined manufactured pulley is permitted. The circumference of any replacement crankshaft pulley must remove at least a minimum of 363mm, this equates to a minimum diameter of at least 115.55mm. The weight of any replacement crankshaft pulley must measure at least a minimum of 600g.

24. THE DISTRIBUTOR & IGNITION SYSTEM.

1. The standard 2 litre Pinto distributor Bosch or Motorcraft must be used.
2. The standard Ford points or electronic ignition using a conventional coil should be used, but as an alternative the Lumination system may be used with the standard ignition coil.
3. No engine management systems are allowed.
4. No multi-spark ignition systems are permitted.
5. The mechanical & vacuum advance may be altered.
6. The vacuum unit may be removed from the distributor.

25. BATTERIES & ELECTRICAL SYSTEM

1. Batteries must be securely mounted in trays, not battery boxes & covered with a rot proof material, if they are not of the sealed type.
2. Battery position is free if fitted between the chassis rails.
3. If batteries are fitted on the outside of the under carriage they must be no further out than in-line with the top main chassis rails.
4. Oversized batteries must not be used as ballast.
5. A battery master switch must be mounted on the dashboard & clearly marked ON & OFF & this must kill all the power to the car.
6. The Battery must sit alongside the chassis with the longest side of the battery next to the chassis not the width if the battery is not square.
7. If an electric fuel pump is used a cut off switch must be positioned within easy reach of the driver so as to isolate the pump.
8. A starter motor must be fitted & working at all times & you may use a competition starter.

26. TRANSPONDER

1. The timing transponder must be fitted to the left-hand chassis rail, 1.8m back from the front of the race car.

27. MIRRORS

1. A rear view mirror is allowed but is not compulsory.
2. Door mirrors if fitted, must not be more than 76mm from the cab.

28. PAINTWORK

1. The external appearance of the car must look professional at all times, drivers of scruffy looking cars will be told to improve their appearance & may not be allowed to race.
2. A maximum of two cars may be painted in team colours or painted to look similar, unless it is required by the Promoter for a particular team event.
3. 100% of the roof must be painted in the correct roof grading unless you are a Superstar or a current Championship holder, when the roof must be painted accordingly.
4. Sign writing must be professional and be approved by the Promoter.

29. SUN VISOR.

1. A Sun visor 165mm or 6" in depth can be fitted to the front screen aperture with your name written upon it.

30. ROOF GRADING

1. All roof grade champions must start at the rear of the Grid, unless told otherwise by an official.
2. If you win a race at a meeting; you will start the remaining races from the rear of your grade. Should you win another race at the same meeting – you will be automatically upgraded.
3. Champions should start in the order of the list below, but multi-Champions will start next to the World Champion.

Grid Line up / Roof Order:

White (Novice)
Yellow
Blue
Red
Silver Stripe – Current Points Leader
White with Red Cross – English Champion
White with a Green Cross – Irish Champion
Blue with a White Cross – Scottish Champion
Union Flag – Best In Britain
Red & White Chequered - Inter Nations Cup

Gold Stripe – National Champion & Red Roof
Black & White Chequered – British Champion
Red & Yellow Chequered – European Champion
Silver – Points Champion
Gold – World Champion

The British Championship, European Championship & National Championship will be classed as open championships.

31. SPECIFICATION AND RULE CHANGES

The Promotion may at any time make amendments to the Specifications for the following reasons:

- In the interests of Safety
- Reduce costs for the driver
- In areas that are detrimental to the future of the formula
- If an unnecessary advantage has been deemed.

32. RACE RECEIVER

All drivers MUST use an official Race Receiver. These will come into effect from 1st March 2020.

Any driver whose Race Receiver is not working when forming the grid prior to a race will not be allowed to race, unless it can be repaired before the race start.

It is strongly recommended that you carry a spare battery either in your overall pocket or taped inside your car.

33. DATA LOGGING

- No data logging is permitted.

34. Engine rules for Spedeworth 2.0 litre Hot Rods & Superstox using Ford Zetec “Black top” 2 Litre engine.

PERMITTED ENGINE

The only permitted Zetec Black top engine is the Ford 1988cc, 16 Valve engine in its 136PS form (codes NGB EDDA-G EBBC EBBD EDDBA EDBB) with nominal bore 84.80mm and stroke 88.00mm. Or new standard un coded Ford replacement complete engine.

Production tolerances are permitted providing the total swept volume does not exceed 1989cc.

ENGINE GENERAL

Engines will be mounted upright, and aligned fore and aft in the chassis.

The addition of any material be it metal, plastic, or composite etc. by any means be it welding, bonding, encapsulation or encasement to any component is prohibited.

However, specific repair of the mounting points of the cylinder block to the transmission or chassis is allowed, whilst other casting repairs may be allowed with prior written approval of Spedeworth.

The use of non-standard replacement fasteners, nuts, bolts, screws, studs and washers which are not connected with, or which do not support, any moving parts of the engine or its compulsorily retained accessories is permitted.

Freedom granted to any fastener does not allow for freedom to move items relative to each other.

For components that are granted the freedom for the fitment of a key or dowel, then material may be removed to allow the fitting of the key or dowel. Only one hole or keyway per component is allowed.

The use of thread locking compounds is permitted.

Gaskets are free however, no competition gaskets are permitted.

Any process of cleaning may be used on any component providing the surface finish, which must remain standard, is not affected.

The expression 'Standard', 'Standard production', or similar expression is deemed to imply that the part has been manufactured by Ford, or a Ford Motor Company Ltd. authorised sub-contractor, for specific use on a specific model of the engine.

Any machining marks on cast components resulting from manufacturing procedures will not cause disqualification. Only machining and component preparation carried out by Ford Motor Company Ltd., or by a Ford Motor Company Ltd. Authorised sub-contractor is allowed unless otherwise specified.

Any production deburring or imperfection removal during initial manufacture may not be modified or extended.

The scrutineer's decision will be final if a dispute arises regarding the amount of tool, or other marks that are evident in any particular component.

The exterior surfaces only (of the complete engine assembly) of ferrous parts may be protected by paint or similar means.

No internal component or surface may be coated by any protective finish. No aluminium components may be protected. The only exception to this is the exterior of the Cam cover/Rocker Cover.

This paragraph confirms previous and future statements that no rework may be carried out on any component unless specifically authorised by Spedeworth.

The engine and associated parts must remain exactly as produced by the Ford Motor Company unless expressly detailed in these regulations.

If the regulation allows a change, then that authorization would allow the change to be carried out. However, any statement defining minimum weight or dimensions does not grant permission for rework to obtain these minimum values, unless carried out in accordance with these regulations.

Only Ford standard parts (Parts manufactured by Ford or a Ford Motor Company authorised sub-contractor) specifically for the 2 Litre "Blacktop" version of the engine can be used in these formulas. No treatment that alters in any way the surface finish, hardness, or other property of the original production component is allowed.

The only exception to this is any deposit derived from the lubrication and combustion processes naturally occurring during the running of the engine. Spedeworth reserve the right to prohibit the use of specific components introduced as production changes, if in the opinion of Spedeworth, they are deemed to have a performance advantage. If in doubt contact Spedeworth.

Engine/transmission mounts attaching to standard Ford components must retain the standard dimensions of the boss or other attachment point without modification.

All motor codes, numbers and build specs etc must be visible and un touched.

CYLINDER BLOCK

It is not permitted, as means of repair, to replace damaged cylinder bores with cylinder liners.

No machining of the cylinder block is permitted except honing/glaze busting of cylinder bores.

The crankcase breather may be modified, including removal, as long as no air and/or oil escape from this area other than through pipe-work to the catch tank.

The piston must be a minimum 10 thou down the bore at top dead centre.

No decking off the block.

Standard oil dipstick tube and dipstick must be fitted.

It is not permitted to remove or modify the four standard oil spray jets.

OIL PUMP

It is not permitted to modify the standard Ford oil pump/front cover in any way.

A pattern part oil pump maybe used.

CYLINDER HEAD (INCLUDING VALVES AND VALVE GEAR).

It is not permitted to replace valve guides and valve seats inserts.

No work that removes, adds, replaces, or transfers material is allowed on the cylinder head with the following exceptions.

a) Simple cleaning which does not alter in any way the shape of the component.

b) Minimal material removal from the head face to correct combustion chamber volume and/or reclaim head flatness. No internal rework of any combustion chamber is permitted. The cam cover assembly cannot be modified or replaced.

The oil filler cap shall be sealed by spring/lock wire or similar.

All valve train components must remain standard.

Valves must remain standard Ford supplied items, no re profiling or polishing is permitted. The original 45° (90° included) seat angle must be maintained.

Standard valve stem seals must be retained.

CAMSHAFTS AND PULLYS

The only permitted camshafts are the standard production camshafts as per picture below.

The camshafts must remain entirely unmodified. It must be fully manufactured and ground by the Ford Motor Company. It is prohibited to grind from blanks, regrind or reprofile. Only the production surface finish is permitted. Shot peening, shot blasting, surface treatments or polishing are prohibited.

Exhaust and inlet camshafts must not be interchanged.

The only permitted camshaft drive pulleys are the standard Ford items. The cam drive pulleys may be keyed to the camshaft by dowel only.

The sprung loaded cambelt tensioner may be locked or replaced with fixed item.

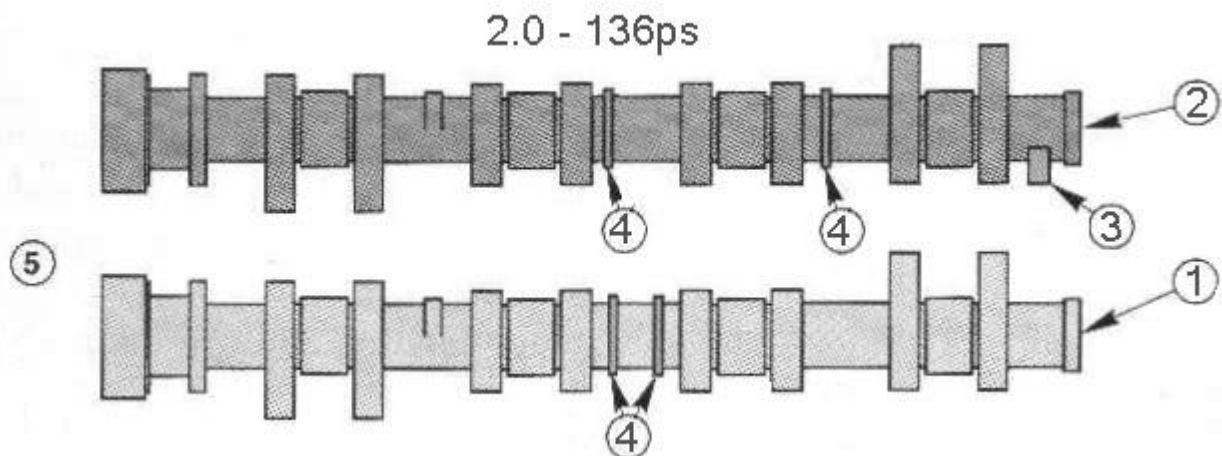

1 Exhaust Camshaft

2 Inlet Camshaft

3 Cam Position Reference - Inlet Camshaft

4 Identification Rings

5 Driving end (pulley end)

CONNECTING RODS

Connecting rods must be standard.

Machining/grinding is not permitted to remove metal from the connecting rod or cap. Polishing is prohibited. Connecting rod bolts are free subject to them remaining in ferrous material, the conrod may not be modified to fit bolts and the minimum weights respected.

PISTONS

Pistons must be standard production pistons unmodified in any way.

All three piston rings must be fitted as intended, piston rings must be standard production items or replacement items to Ford Motor Co. dimensions.

CRANKSHAFT

A standard crankshaft must be used. No balancing is permitted.

Polishing other than the 9 bearing surfaces is prohibited.

Crankshaft journals must remain within Ford positional tolerances if a repair regrind is carried out.

Crankshaft pulley and damper must be retained and un modified.

Additional drives to water pump may use this pulley, or extra pulleys mounted in front of the crankshaft damper.

It is not permitted to alter the number of bearings or fit bearings of less than standard production width.

The crank journals may be reground for reclaim. Standard oversize and undersize bearings are permitted.

A marker must be fitted which accurately aligns the crankshaft to the cylinder block at No.1 piston TDC. This marker must be visible and fully accessible to the scrutineer's without removing any component other than external bonnet panels, and without removing the engine from the car.

ENGINE COVERS

The cam belt covers cannot be modified or deleted.

FLYWHEEL AND CLUTCH

The mandatory steel flywheel supplied by Spedeworth may not be modified in anyway.

Flywheel bolts are free subject to them remaining in ferrous material. No modifications to either crankshaft or flywheel in order to fit is permitted.

Clutch to be standard Ford Pinto based 8.5" (8 1/2") item only. No competition items.

Standard Ford Pinto based starter motor must be fitted. ***Competition starter motors maybe used.***

SUMP AND PICK UP PIPE

Oil sump and oil pick up pipe are free.

OIL FILTER

Oil filters are free but must have a secondary fixing.

OIL COOLERS

No oil cooler is permitted.

COOLING SYSTEM

A water based liquid cooling system is mandatory. The standard production water pump and housing must be retained, although drive to the pump, its rotational speed and direction may be changed. The radiator and associated pipes are free.

No other pump may be used to circulate or assist circulation of the coolant liquid. Thermostat housing is free.

ENGINE IGNITION CONTROL UNIT (ECU) AND ELECTRICAL

The only means of ignition will be by use of Ford crankshaft speed sensor fitted to the std manual sensor housing and Ford based ignition coil. No other sensors engine or chassis permitted.

The mandatory engine ignition control unit (ecu) and wiring loom supplied by Spedeworth will be registered to driver and electronically sealed. Neither can be modified in any way.

The engine ignition control unit (ecu) and/or any other ignition components may be exchanged, or electronically interrogated at any time (including the time allocated for practice or testing) upon the request of a designated official from Spedeworth.

It is prohibited to use any other method or component to trigger, distribute or time the ignition.

The coil unit may be repositioned, the HT leads to the sparking plugs are free.

Sparking plugs are free, provided they fit the engine without any modification to the cylinder head or the sparking plug and that the sparking plugs place the spark gap in the same position as the production sparking plug within the combustion chamber.

The ECU diagnostic connector must be positioned in an accessible position, allowing the scrutineer free access to it at all times.

INLET MANIFOLD

Mandatory inlet manifold supplied by Spedeworth may not be modified internally.

Standard manifold to head casting gasket or silicone based sealer may be used to seal face to cylinder head only. At any point in time Spedeworth can introduce the fitment of a restrictor plate fitted between manifold and carburettor mounting plate of any given size if it is deemed suitable to reduce the output of any engine at any time before during or after any practise, testing or racing. ***The inlet manifold must be sealed with the O-Rings supplied or if required instant gasket sealant can be used, No other method can be used.***

CARBURETTOR

a. Only the standard Weber 32/36 DGV/A carburettor may be used with a maximum sized chokes of 26mm and 27mm.

b. No polishing or re-profiling is allowed.

c. No modification to the carburettor body or original design. The interchanging of the carburettor top from other Weber models is not allowed but ***float bowl vent & the air correction jet vent, & the idle jet vent may be modified.***

d. Gaskets must be original or replicas of original (i.e. no modified gaskets).

e. A single original specification adapter/insulator block must be fitted between carburettor and inlet manifold, with two gaskets approximate total thickness 5mm I.E. as supplied with Gasket set.

f. Main jets, primary and secondary jets, auxiliary venturi, and emulsion tubes may be replaced with a different size of the same part.

g. Accelerator pump jets may be changed but face downwards towards butterflies.

- h.** Butterflies may be modified to open together, replacement spindles may be fitted with standard screws. Cold starting devices may be removed, with retaining lugs and subsequent holes blanked off.
- i.** Air and fuel galleries may not be enlarged or modified; fuel may enter needle valve/float chamber from either side. Floats may not be modified or weighted, and must control the fuel flow.
- j.** Needle valves may not be larger than 250 and not enlarged or modified.
- k.** The power valve must be fitted in the base of the fuel bowl, but may be sealed off, and the diaphragm may be removed.
- l.** No trumpets are allowed. The calibrated brass bush which controls the high speed enrichment, fitted on the secondary venturi side of the carburettor between the top and base of the carburettor, may be sealed off or enlarged, but must be fitted.
- m.** A secondary fixing on the fuel feed-line is required. It is permitted to use a grub screw, or similar device, to fix the auxiliary venturi to the carburettor body.

IT MUST BE CLEARLY UNDERSTOOD THAT THE OVERRIDING PRINCIPLE OF THESE REGULATIONS IS THAT UNLESS IT IS STATED THAT YOU CAN DO IT, YOU SHOULD WORK ON THE PRINCIPLE THAT YOU CANNOT.

Whilst Spedeworth will endeavour to inform Competitors of any changes of components or specification they reserve the right to do so at any time during the life of these Regulations.

Exhaust Manifold

At the moment we are going to try and keep the exhaust manifold standard on the four branch manifold.

Zetec's are permitted to run a 4 into 1 four branch manifold.

You may polish the exhaust system on the outside if you wish.

No ceramic coating or any other coating is allowed except heat wrap.

The following parts have to be brought from Spedeworth Motorsport

- 1. Inlet Manifold**
- 2. Flywheel**
- 3. Ignition pack and wiring loom**

These are all numbered parts, so to buy these items please call 01252 322934

From the 11th April 2020, All Zetec engines must be using the Latest spec Spedeworth flywheel & not the IKE model. Also, must be on the OMEX ECU & Wiring Loom. Another ECU as been added to the list, this being the Spedeworth Nodiz.

Protest Zetec Engine Buying Price Announcement

Spedeworth / Incarace would like to announce that the protest buying price for the Zetec engine for the Superstox will be £1500 + VAT.

The buying price of the Zetec engine is the price to be paid to buy and protest another driver's engine at a race meeting. *To buy the engine you have to be a licenced driver to this formula and racing at the event or the promoter. The driver buying the engine can be kept anonymous.*

This price does not include the inlet manifold, Carburettor, clutch and flywheel, wiring loom or the ECU.

Spedeworth / Incarace are looking to make short oval racing more affordable for drivers and to encourage more drivers into the sport and we believe that this is another way of achieving this goal.

REVISED RULES FOR 2025 IN BOLD/ITALIC/*RED* PRINT.

ITEMS MARKED ~~STRIKETHROUGH~~ ARE NO LONGER ALLOWED

[2025 Superstox Technical Specifications Issue 1, Dated 21st January 2025.](#)