

# 2022 LIGHTNING RODS - **DRAFT** SPECIFICATIONS, RULES AND REGULATIONS



## CONTENTS

1. CARS	2
2. ENGINE	2
3. EXHAUST SYSTEM	3
4. CARBURETTOR & INLET MANIFOLD	3
5. GEARBOX & DIFFERENTIALS	3
6. FRONT SUSPENSION	3
7. REAR SUSPENSION	4
8. STEERING	4
9. WHEELS & TYRES	4
10. BRAKES	4
11. BODYWORK	4
12. ROLL CAGES	5
13. SCREEN	6
14. STOP LIGHTS	6
15. SEATS	6
16. BATTERIES & ELECTRICAL	8
17. NUMBERS	9
18. FUEL SYSTEM	9
19. FUEL	9
20. ZETEC ENGINE	9
21. WEIGHT	13
22. TRANSPONDERS	13
23. RACEIVERS	13
24. SAFETY EQUIPMENT	13
25. DATA LOGGING	13
26. THE MALCOLM GIRLING RULE	13
27. GRADING & START POSITIONS	14
28. ALL OVAL RACING FORMULAE	15

## **VIOLATIONS**

When referring to the engine, gearbox, differential, mechanical or construction, rules and regulations the principle will always be: Unless permission is specifically granted to make modifications, or any variation, nothing may be done to alter or change in any way the standard Parts.

**IT MUST BE CLEARLY UNDERSTOOD THAT THE OVERRIDING PRINCIPLE OF THESE REGULATIONS IS THAT UNLESS IT IS STATED THAT YOU CAN DO IT, YOU SHOULD WORK ON THE PRINCIPLE THAT YOU CANNOT.**

Whilst your Promoter will endeavour to inform Competitors of any changes of components or specification they reserve the right to do so at any time during the life of these Regulations.

**Cars, Engines and Fuel will be checked on a random basis.**

**Violations will result in an immediate suspension of all racing facilities and any refusal will also result in an immediate suspension.**

**All car and engine specifications will be taken from the Technical Service Data book for cars as published by Glass's Guide Service Limited.**

Drivers are reminded that scrutineering checks can be carried out at any time, and most certainly at official championships. If parts are suspected of being illegal make sure you leave them with the promotion if you do not agree. If you refuse it will automatically make the parts illegal. **It is the responsibility of the driver to prove to the promotion that the part is legal by the way of written proof of where the part originated. This must be done within seven days, otherwise the part(s) in question will be deemed to be illegal and will result in immediate suspension from racing and referral for disciplinary action.**

### **1. CARS**

Only right-hand drive Ford Sierra (hatchback or saloon cars) and **BMW E36 (Saloon or coupe)**, BMW E46, **BMW E90**, Toyota Lexus IS200 are permitted. Other cars maybe considered with the promotions permission but no compact models. Only one driver per car and one car per driver is permitted at each meeting.

***On these new model cars, negative camber can only be achieved by moving the top mount, but it can not be adjustable, this is on the passenger side only.***

### **2. ENGINE**

**You may use the Ford 2 litre Pinto or the Ford Zetec "Black top" 2 litre engine. Specification for the Zetec engine are detailed.**

**The Ford 2 litre Pinto engine must be in standard form but may have a modified camshaft and may be prepared to the following specifications:**

- a) Nominal bore size 90.84mm plus 1.5mm oversize. Standard stroke 76.95mm.
- b) Block and head may be skimmed but the pistons may not protrude above the block. Pistons may not be skimmed or modified in any way. A standard crankshaft must be used.
- c) Engine balancing : CRANKSHAFT – spot machining only; CON RODS – Spot machining only on the counter weight balance pad area at the big and small end. ONE con rod must remain original and untouched. Con rod bolts may be changed but con rods must not be drilled or modified to accept them; PISTONS – Spot machining only and one piston must be original and untouched. All four pistons must have original marking on crown. NOTE: Spot machining means you can either hand grind, drill or machine.
- d) Only standard pistons or standard replacement pistons (i.e. KS Karl Schmidt, Mahle, Hepolite/Wellworthy AE) may be used. Any make of piston ring may be used providing the number of rings remains the same as standard and no machining of the pistons or rings other than gapping is required. No forged pistons are allowed. (See 2c for balancing).
- e) Camshafts are free, vernier cam wheels may be used and any single valve spring may be used that fits without any modification to the standard spring tops. Extended ball studs are permitted. Rocker arms are free with the exception or roller rockers. Heavy-duty valve retaining caps are permitted for use. Camshaft centre main bearing caps may be strapped.
- f) Head: You may use any standard 2 litre S.O.H.C. Sierra/Pinto head. No modification is allowed except valve spring seats may be machined. Any single or double valve springs may be used, and the head may be modified to allow them to fit Including Shimming.
- g) Valves must be standard and of standard Ford length. N.B. On Standard Ford Inlet Valves only, where the back of the valve meets the valve seat, there may be a slight lip, this may be ground away at a 30° angle, to a maximum width of 2.5mm. Over size valve stems are allowed, and valve seats may be re-cut. A three angle valve seat may be used to the following specification: Angle 1 – Combustion Chamber 30°, Angle 2 – Valve Seat 45°, Angle 3 – Port 60° - 65°, with valve seat width free. No gas flowing or adding of material to the ports or combustion chamber. Replacement valve guides may be used but must use original position. Bronze valve guides are not permitted, but thin wall bronze inserts may be used.

- h) Flywheel and Clutch: Any standard Pinto engine flywheel may be used which may be lightened. Only the standard type clutch may be used. Flywheels MUST be dowelled to the crank. An approved steel flywheel is available from Turbosport. Contact 01489 406886.
- i) Competition starter motors can be used.
- j) No competition gaskets allowed. Only Ford, Payen or standard American version may be used.
- k) Standard Motorcraft or Bosch distributors must be used with either points and condenser or electronic ignition. \* See rule 14. The mechanical advance may be altered, and the vacuum advance may be altered or removed.
- l) Engine Mounts: Engine mounting brackets must remain standard, but the mounting may be modified. The engine must occupy its original position. The charging system: Power steering pumps may be removed, fan belts are free but standard pulleys must be used. Blocks may be re-bored to size, sleeved, line bored and surface ground. No other modifications are allowed. Sumps: No alloy sumps. Standard steel sumps must be used. Pick up pipes may be modified and sumps may be baffled. No outside alterations may be made.
- m) Oil coolers may be fitted using a sandwich plate between the oil filter and block. Oil coolers must be fitted within the engine compartment. No remote oil filters.
- n) The engine must be fitted with a metal catch tank of 1 litre minimum capacity. It must have a minimum of 2 breather pipes connected to it, one from the rocker box and one from the crankcase. The only modification allowed to the rocker cover is for breathing purposes only.
- o) No turbos, no fuel injection, no forced induction of any kind.
- p) The exhaust manifold must be in standard form and standard to the Sierra/Pinto 2 litre. The inlet manifold must be standard with the exception of water circulation holes, which may be blanked off.
- q) All engine parts not mentioned above must remain standard.
- r) Water cooling systems may be modified, provided that all modifications are inside the original bonnet outline.
- s) Cables are free.

### **3. EXHAUST SYSTEM**

The standard exhaust system may be retained, or AX891, Laws or Simpson ORC225 or Edwards exhaust silencer. A minimum of 2" (50mm) and a maximum of 10" (254mm) section of tail pipe must be fitted to the silencer facing rearwards or down - THIS WILL BE MEASURED FROM THE REAR OF THE BOX (NOT THE PIPE). The front downpipe must remain standard; you may weld a maximum 1½" (38mm) plate in between 2 down tubes to stop them breaking off and you may, at the bottom of the downpipe, fit a fuel mixing sensor the front downpipe can only be modified at the tail end to allow the exhaust to run through the car, by shortening by up to 1". . The flange may be removed & the exhaust maybe welded to the downpipe. If exhaust systems pass through the car they must be covered. If a silencer becomes ineffective during racing or practice, the car will be withdrawn from the event. Exhaust must terminate towards the rear of the car and may not terminate through the side of the car.

A standard copy down pipe may be made but must be same length and measurements as a standard ford down pipe.

### **4. CARBURETTOR & INLET MANIFOLD**

Only the standard Weber 32/36 DGV or DGVA carburettor may be used with a maximum of 26mm and a 27mm sized chokes. No polishing or re-profiling is allowed. No modifications to the carburettors body or original design. The interchanging of the carburettor top from other Weber models is not allowed. All gaskets must remain standard and original. A single original spec insulator block must be fitted between carburettor and inlet manifold, with two gaskets; approximate total thickness = 5mm. Main jets, primary and secondary jets, auxiliary venturi and emulsion tubes may be changed but must face downwards towards the butterflies. Accelerator pump jets may be changed but face downwards towards butterflies. Chokes may be modified to open together and replacement spindles may be fitted with standard screws. Cold starting devices may be removed with retaining lugs and subsequent holes blanked off. Air and fuel galleries may not be enlarged or modified, and fuel may enter on either side. Floats may not be modified or weighted, and must control the fuel flow. Needle valves may not be larger than 250, and not enlarged or modified. The power valve must be fitted in the base of the bowl, but may be sealed off, and the diaphragm may be removed. No trumpets are allowed. It is permitted to use a grub screw or similar device to fix the auxiliary venturi to the carburettor body. Top end enrichment devices may be blanked off or modified. A secondary fixing on the fuel inlet feed line is required. The Inlet manifold must be standard & not faced to alter the angle of the manifold to the carburettor. No inlet port matching of the carburettor to the manifold or the manifold to the head. No material may be added or removed from the gas flow area, it must be as standard.

### **5. GEARBOX & DIFFERENTIALS**

Must be standard to the range and fitted by the manufacturer with the exception that the P100/Ford Cortina gearbox may be fitted into the Sierra **& new model cars**. All gearboxes must have a conventional type bell housing and the gear change must require a clutch and must be operated by a lever arm. No competition type gearboxes allowed. No aluminium bell housings allowed. Differential ratios are free and may be locked by welding only. No limited slip differentials, no Cosworth, XR4 or 4 x 4 parts to be used. No torque biasing assemblies. Axle and diff must remain the same concept as original. Propshaft is free. Gear sticks are free. The differential must not be moved in any way from its original position.

**New model cars can use the RX8 Gearbox plus all the gearboxes above**

### **6. FRONT SUSPENSION**

~~Positive camber on the offside front wheel is allowed, this can only be achieved by the drilling of the cross member only~~  
The offside bottom arm must remain standard length, the anti-roll bar may be modified to suit. Negative camber on the nearside front wheel is permitted but not adjustable. This may be achieved by re-drilling the cross member AND lengthening the nearside bottom arm by a maximum of 2" the roll bar may be modified accordingly. Anti-roll bars may be modified to suit. **This is for sierra cars only.** Lengthening must not be achieved with threaded bar. ~~Positive camber on the O/S front wheel is allowed.~~ **Drivers side front wheel, when the car is parked the wheel must be either upright or have negative camber, No positive camber is permitted. To achieve this you may re drill the cross member to achieve upright but this cannot be adjustable & you may shorten the steering rack arm on the drivers side.** The springs are free and the car maybe lowered. All suspension parts must be located by original mounting points on the chassis and body, with the exception of front bottom-arms. Solid bushes are allowed but not competition or Cosworth type. ~~Poly bushes are not allowed.~~ The exception to this is that you may re-drill a maximum of two extra holes (one on each side) in the front cross member bottom arm-location. Strut braces may only be fitted on the front struts and may be triangular shape and bolted to the bulkhead **or the roll cage, but must not go forward of the centre of the strut.** Top mounting plate may be modified to locate 2¼" springs. Dampers may be up-rated, the Leda leg with non-standard spring platform & the Gaz equivalent may be used, but no metal must be added to them. These shockers can only be valved by the original manufacturer.

Poly solid bushes may be used.

**The above is for sierra only.**

**All new models must remain on standard Suspension including bushes, except for springs. You may use uprated shockers but not adjustable & if re valved must be re valved by the original manufacturer. Bilstein are not allowed.**

**On these new model cars, negative camber can only be achieved by moving the top mount, but it can not be adjustable, this is on the passenger side only.**

**Anti Rollbars maybe removed.**

## **7. REAR SUSPENSION**

The components are to be standard & original in length, but may be upgraded. No adjustable parts, fixed or otherwise are allowed. No other modifications are allowed. ~~Only standard bushes are permitted,~~ no competition parts. Suspension may be lowered. Springs are free. Negative camber may only be achieved by shimming the drive shaft location. The drivers side rear wheel cannot have any positive degrees on it at any time but it can be adjusted by washers only. No rear Steer. Top spring cups maybe modified to take 2¼" springs. Poly solid bushes may be used.

**This is for sierra cars only.**

**New model cars may archive negative camber buy modifying the back arm/arms but must be welded and not adjustable on passenger side only. This does not include the adjustment which is standard from manufacturing.**

## **8. STEERING**

The Steering rack must occupy it original position, & manual racks can replace PAS systems. Quick racks can also be used. The steering rack arms may be modified: Nearside rack arm may be lengthened, the Offside may be shortened.

**This is Sierra Only.**

**All new models must remain standard**

The steering column height may be adjusted & reinforced at the top bracket. A quick release steering wheel is compulsory.

## **9. WHEELS AND TYRES**

Any steel or alloy wheel can be used to a maximum of 7" **but NO Spilt Rims.** Wheel studs are free but must be flush with the wheel nut minimum but must not protrude the nut by more than 3 threads. No wheel spacers allowed, whether welded to the wheel or not, unless fitted as standard. ~~The only tyre permitted is the Yokohama 185 / 70 x 13~~

~~AO21R, compound No. T567.~~ **The sierra must use 175/70/13 Yokohama Blu Earth ES32 Tyre. Run off period for the AO21R is the 31<sup>st</sup> May 22.** Gaiters are not permitted. No alteration can be made to the original tread pattern by tyre cutting. ~~Tyre choice is currently free on BMW models.~~ **New model cars must use the standard wheels to what the car is manufactured on whether steel or alloy, If the car is made with a 16" wheel, you must use a 16" wheel. All 4 wheels must be either steel or alloy not 2 & 2.**

**Tyres permitted only are Yokohama Blu Earth ES32 – 15" Wheel must use to a maximum 195/15, 16"/17"**

**Wheel must use to a maximum of 205/16-17.**

~~promoters will be looking towards the restriction of the use of new tyres.~~ Tyre softener or any tyre contamination is not permitted.

**Tyre Buffing is permitted, this can not be done at the track.**

## **10. BRAKES**

To be original and to work on all wheels. Handbrake is compulsory. No biased braking. No ABS, no 4 x 4 or Cosworth parts allowed. Brake pipes may be allowed to pass through the car. The use of competition brake pads is permitted, however, the use of competition brake pipes is not allowed.

**All new models may change the servo or master cylinder valve but must not use any competition type.**

**This is due to cars having front - back braking this will be looked into during the year.**

## **11. BODYWORK**

To remain standard including floor pan with removal of inner door panels permitted but any removal of structural stiffeners is not permitted, with the exception of the bonnet and boot **stiffeners & Rear Parcel Shelf**. No holes are allowed in any panel, other than original. On two door shells, the inner skin may be removed between the B and C posts below the waistline of the car. No armouring whatsoever. All doors must be fixed closed when racing. No spoilers or aerofoils unless fitted as standard to the range of car. ~~Grilles must remain in their original position.~~ Replacement grilles must be made of plastic. Fibreglass grilles are allowed and may include headlamp apertures. Front and rear light apertures may be blanked using a maximum thickness of 2mm aluminium and must not overlap apertures by more than 25mm. Headlamps may be blanked on the front or back of the apertures. All flammable material must be removed. Any replacement dashboards for gauges etc. **must be made of aluminium or fibre glass**. Wheel arches may be relieved to a maximum of 2" but the original shape must be retained. They may be re-welded, but no adding of extra metal and no sharp edges should remain. A metal upright  $\frac{3}{4}$ " x  $\frac{3}{4}$ " must be welded or bolted into the windscreen aperture, one third of the way along the driver's side. Plastic bumpers must remain in place. **No steel rear bumpers from the 1<sup>st</sup> of July 2021.** In addition Rover 400 Series/Rover 45 or Ford Escort Mk V bumpers may be used as replacements. Additional means of fixing are allowed, but these must not be used as armouring. All fixing bolts must be the coach bolt type with the head of the bolt facing outwards. Standard lifting/towing eyes must be retained. No foam filled panels are allowed. Fabricated doors including the rear quarter are allowed, but must be of professional appearance; the maximum thickness of steel sheet used must be 1mm. **All the new model cars must remain on their standard original bumpers and panels but maybe skinned.** There must be no overlapping and should be no thicker than original. **Fibre Glass Front/Rear bumpers are permitted and should consist of a maximum of three layers, one of which maybe KEVLAR, these panels must be purchased from Spedeworth fabrications.** The total maximum bumper thickness allowed is 10mm. The circular area of the spare wheel carrier may be removed but must be replaced with a steel plate of equal thickness to the original metal – You may not remove any other sections of the boot floor.

**All new model cars must keep the grille in its original position.**

**All new model cars must remain on the standard original bumpers, you may modify the impact bars.**

**All new model cars with no inner front flitches may put 1 piece of 1" box or tube to support the front wing & edge of front bumper.**

**Bulkheads & gearbox tunnels cannot be cut out in anyway, but can be knocked out to fit gearboxes.**

## **12. ROLL CAGES**

The minimum requirement is a four post roll cage with down bars in support of the A & B posts, constructed from mild steel members, minimum size of 32mm x 32mm x 3mm, or 38mm x 38mm x 2.5mm box or tube, all securely welded at all joints as shown and must include the following.

1. A 230 mm square plate, minimum 3mm thick, welded between the base of the uprights and the floor for additional strength
2. One horizontal bar between A Posts (at dashboard level)
3. One horizontal bar between B posts at approximately mid height and adapted to form support to the seat / seat headrest or a seat hoop.
4. Two "chicken" bars in the drivers door aperture and two in the passenger door aperture. Chicken bars to fit between A & B post support down bars and no further. Chicken bars must have a minimum of two connecting bars to join them both together made of a minimum of roll cage material but may be thicker to help with weight. If the bars cross they must have two extra connecting bars so it is not just a cross in the middle as shown in the diagram below. Bars that lay on the sills will not be classed as chicken bars.
5. Two down bars, one each side from the roll cage top, to either, the rear suspension turret (5) or (5A) into the boot well, terminating 100mm short of the back panel.

The following members may be added (to the same material specification as the roll cage :

6. Two bars, one each side, from the B post down bar base, rearward to the suspension turret.

## **ROLL CAGE DIAGRAMS**

### **MINIMUM SPECIFICATION ROLL CAGE**

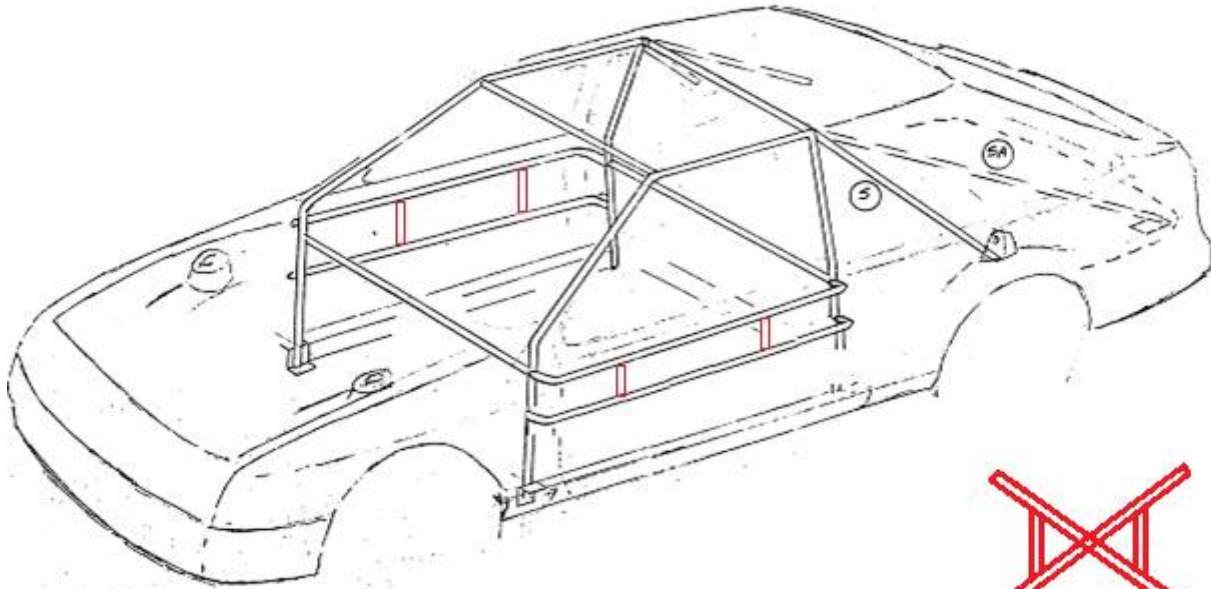

If cross is on the passenger side you must have the two connecting bars as shown here.

### **MAXIMUM SPECIFICATION ROLL CAGE**

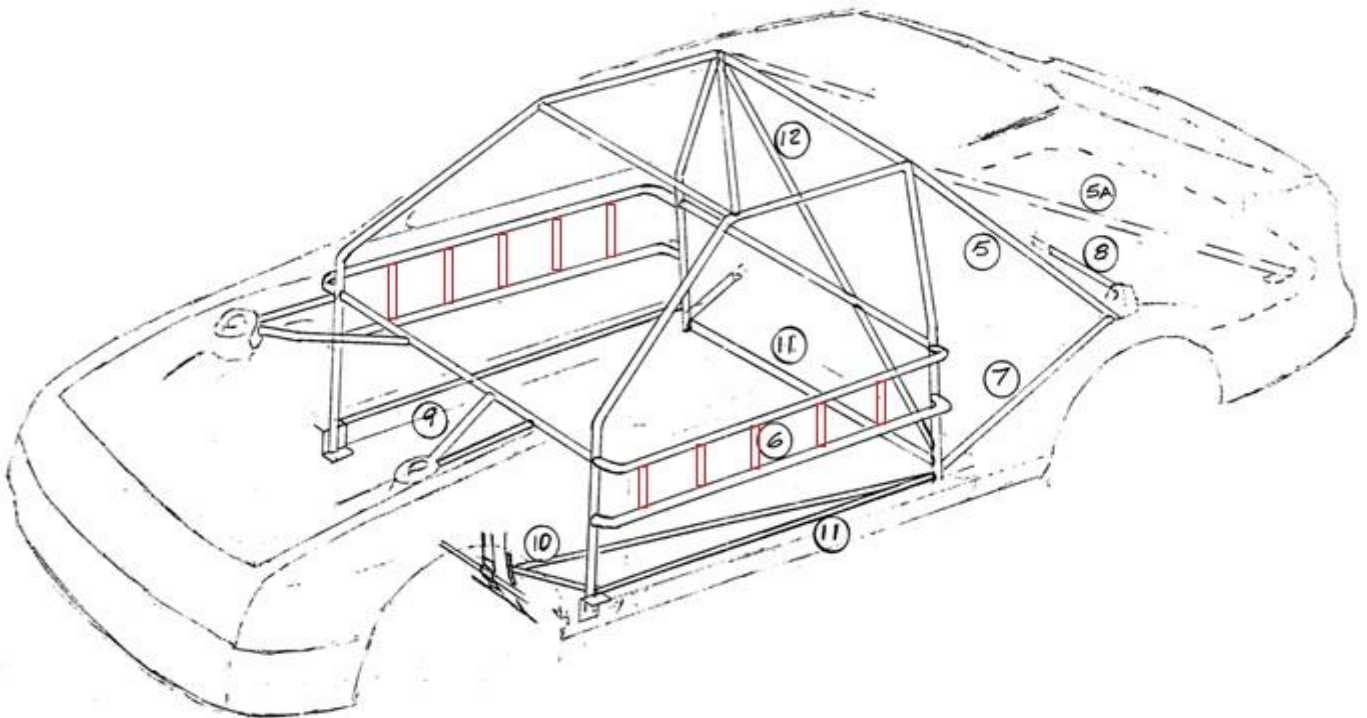

7. A cross bar fitted across the rear suspension turrets, this may be cranked and welded to the floor panel in a central location.
8. Members may be positioned from the roll cage, forward through the bulkhead and connected to the front suspension turrets. Members must be within the engine bay aperture and horizontal (within practical limits)
9. Additional bars in passenger side to support front roll bar, rear mounting area (in the footwell). Bars must be positioned low down such that access to the driver is not limited.
10. One horizontal bar each side between A & B post support down bars at sill height and between B posts (to protect legs/feet in a side impact situation).
11. One diagonal member between either B post support uprights or rearward members described in (5)

#### **Further Notes**

No suspension components may be fixed directly to roll cage / support members.

All members must be positioned within the body lines and fitted as supports/protection NOT armouring.

No other members must be added as the list above describes the full limit of roll cage construction that is allowed.

**Please refer to the roll cage diagrams which illustrate the minimum required and the maximum allowed.**

### **13. SCREEN**

All glass must be removed. Front screen must have a central bar of 19mm x19mm or 3/4" x 3/4" SHS welded in place. An interior mirror must be fitted. A drivers door mirror must be fitted, mounted in such a position that it does not project further out than the body. (Must not be able to get knocked off whilst in racing traffic).

**A mesh panel covering the driver's side of the screen is permitted, but must be fitted in a way to be easily ripped off IE Cable tied in.**

### **14. STOP LIGHTS**

Either two stop/brake lights or one single stop/brake strip-light must be fitted facing rearwards. If two lights, they must be a minimum of 30 inches (762 mm) apart. Lamp(s) must be operated by the standard stop light switch as fitted to the particular model of car. No other switches or modifications to switches to be made. Bulbs to be of 21 watt intensity. For round type lamps: minimum diameter 3" (76mm), maximum diameter 5" (127mm). For square/rectangular type lamps: minimum 3" (76mm) square, maximum 5" (127mm) square. For strip type lamps, minimum of 8" (203mm), maximum of 16" (406mm) width and should be fitted securely to allow a clear view from the rear. All bulbs must be working. **All brake lights must be Red.**

### **15. SEATS**

You must have a Competition type Driving Seat with a head restraint.

The seat should occupy its original position where possible and be suitably supported at shoulder height and on both of the sides and back, with a suitable framework or seat stiffener's.

**If the seat sits behind the b/pillar hoop a secondary support to the cage must be added. An example of this is shown in the diagrams within this section of the document. If the modification goes to the floor it must be sat on 23cm square plate 3mm (min.) thick.**

**This new section must not be constructed in a way that a drivers helmet can make contact with it.**

**Material od and thickness as rest of roll cage.**

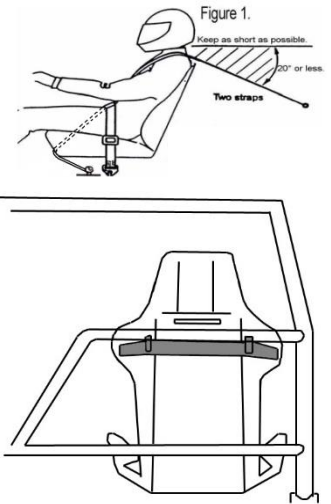

# FRONT VIEW

SECONDARY SEAT SUPPORT BARS





## **16. BATTERIES & ELECTRICAL**

May be brought inside the car, but the floor must not be cut to accommodate the battery. They must be firmly fixed and covered with a material which will not rot due to acid contamination. Batteries must be a minimum of 6" (152mm) from fuel tank. An electrical cut off switch must be fitted to the R/N/S corner of the car **& this must kill all the power to the**

**car.** If Lumination is used they must be of the following part nos: Ford: Bosch fitting kit FK221 power module PMA50, Motorcraft FK9 PMA50. A 24 volt starter system is permitted.

## **17. NUMBERS**

The driver's racing number must appear on the doors of the car. They should be preferably in large American style numbers on a contrasting background. The bigger the better. You should also paint your number in black on white or white on black in the rear corner of your roof to assist with lap scoring at tracks with race controls that are located in a high position. A 'Sun Visor' made of metal and having a depth of at least 6" must be fitted to the top of the windscreen aperture when no laminated glass or perspex is fitted. The drivers name only must appear across the sun visor position. All signwriting must have a professional appearance.

Scrutineers will instruct drivers to change their numbers if lap scorers find it difficult to read them. The whole of the roof of the car (with the exception of number triangle) must be painted in the drivers current grade colour.

*Fin numbers are optional must be Black 9" high in 1½" strokes minimum. The fin plate must be black numbers with a white background with the bottom fitted on or above the roof gutter but be no higher than 12" in total from the roof. If a driver chooses not to run a fin plate then the number must still appear on the roof. All numbers must be of professional appearance.*

If you win a race at a meeting; you will start the remaining races from the rear of your grade. Should you win another race at the same meeting – you will be automatically upgraded.

## **18 FUEL SYSTEM**

Fuel tanks must be metal or FIA approved with a maximum capacity of 4 gallons or less are permitted. These must be fitted rear of the driver but in front of the rear axle centre line, i.e. they are no longer allowed to be fitted in the boot area. They **MUST NOT BE FITTED BELOW THE CHASSIS RAILS** of the car, and the floor must not be cut in any way to accept the tank. All tank filler caps must be of a secure leak proof metal or screw fitting. Petrol pipes must be of metal or metal covered and have a shut off tap within easy reach of the driver. All tanks must be fitted with a breather system which prevents spillage if a car is inverted. The fuel tank must be a minimum of 6" (152mm) from the battery. All petrol pick up pipes must draw through a stand pipe from the top of the fuel tank. Four 2" holes must be drilled at the lowest point under tanks to allow spilled petrol to drain. A firewall between fuel tank including filler cap/pump and driver must be fitted. Fuel regulators may be used.

## **19 FUEL**

For the full fuel specification please see back page.

## **20. ZETEC ENGINE**

The only permitted Zetec Black top engine is the Ford 1988cc, 16 Valve engine in its 136PS form (codes NGB EDDA-G EBBC EBBD EDDB) with nominal bore 84.80mm and stroke 88.00mm. Or new standard uncoded Ford replacement complete engine. Production tolerances are permitted providing the total swept volume does not exceed 1989cc.

Specifications of the Zetec Engine are further detailed below as follows :

### **20a : ENGINE GENERAL**

- a) Engines will be mounted upright, and aligned fore and aft in the chassis.
- b) The addition of any material be it metal, plastic, or composite etc. by any means be it welding, bonding, encapsulation or encasement to any component is prohibited. However, specific repair of the mounting points of the cylinder block to the transmission or chassis is allowed, whilst other casting repairs may be allowed with prior written approval of Spedeworth.
- c) The use of non-standard replacement fasteners, nuts, bolts, screws, studs and washers which are not connected with, or which do not support, any moving parts of the engine or its compulsorily retained accessories is permitted.
- d) Freedom granted to any fastener does not allow for freedom to move items relative to each other. For components that are granted the freedom for the fitment of a key or dowel, then material may be removed to allow the fitting of the key or dowel. Only one hole or keyway per component is allowed.
- e) The use of thread locking compounds is permitted.
- f) Gaskets are free however, no competition gaskets are permitted.
- g) Any process of cleaning may be used on any component providing the surface finish, which must remain standard, is not affected.
- h) The expression 'Standard', 'Standard production', or similar expression is deemed to imply that the part has been manufactured by Ford, or a Ford Motor Company Ltd. authorised sub-contractor, for specific use on a specific model of the engine.
- i) Any machining marks on cast components resulting from manufacturing procedures will not cause disqualification.
- j) Only machining and component preparation carried out by Ford Motor Company Ltd., or by a Ford Motor Company Ltd. authorised sub-contractor is allowed unless otherwise specified.

- k) Any production debarring or imperfection removal during initial manufacture may not be modified or extended. The scrutineer's decision will be final if a dispute arises regarding the amount of tool, or other marks that are evident in any particular component.
- l) The exterior surfaces only (of the complete engine assembly) of ferrous parts may be protected by paint or similar means.
- m) No internal component or surface may be coated by any protective finish.
- n) No aluminium components may be protected.
- o) The only exception to this is the exterior of the Cam cover/Rocker Cover.
- p) This paragraph confirms previous and future statements that no rework may be carried out on any component unless specifically authorised by Spedeworth. The engine and associated parts must remain exactly as produced by the Ford Motor Company unless expressly detailed in these regulations. If the regulation allows a change, then that authorization would allow the change to be carried out. However any statement defining minimum weight or dimensions does not grant permission for rework to obtain these minimum values, unless carried out in accordance with these regulations. Only Ford standard parts (Parts manufactured by Ford or a Ford Motor Company authorised sub contractor) specifically for the 2 Litre "Blacktop" version of the engine can be used in these formulas.
- q) No treatment that alters in any way the surface finish, hardness, or other property of the original production component is allowed. The only exception to this is any deposit derived from the lubrication and combustion processes naturally occurring during the running of the engine.
- r) Spedeworth reserve the right to prohibit the use of specific components introduced as production changes, if in the opinion of Spedeworth, they are deemed to have a performance advantage. If in doubt, contact Spedeworth.
- s) Engine/transmission mounts attaching to standard Ford components must retain the standard dimensions of the boss or other attachment point without modification. All motor codes, numbers and build specs etc must be visible and un touched.

### **20b : CYLINDER BLOCK**

- It is not permitted, as means of repair, to replace damaged cylinder bores with cylinder liners.
- No machining of the cylinder block is permitted except honing/glaze busting of cylinder bores.
- The crankcase breather may be modified, including removal, as long as no air and/or oil escape from this area other than through pipe-work to the catch tank.
- ~~• Pistons must not protrude above block deck face at any point.~~
- **The piston must be a minimum 10 thou down the bore at top dead centre.**
- **NO Decking of the block.**
- Standard oil dipstick tube and dipstick must be fitted.
- It is not permitted to remove or modify the four standard oil spray jets.

### **20c : OIL PUMP**

- It is not permitted to modify the standard Ford oil pump/front cover in any way.

### **20d : CYLINDER HEAD (INCLUDING VALVES AND VALVE GEAR)**

- It is not permitted to replace valve guides and valve seats inserts.
- No work that removes, adds, replaces, or transfers material is allowed on the cylinder head with the following exceptions.
  - ❖ Simple cleaning which does not alter in any way the shape of the component.
  - ❖ Minimal material removal from the head face to correct combustion chamber volume and/or reclaim head flatness.
- No internal rework of any combustion chamber is permitted
- The cam cover assembly cannot be modified or replaced.
- The oil filler cap shall be sealed by spring/lock wire or similar.
- All valve train components must remain standard.
- Valves must remain standard Ford supplied items, no re-profiling or polishing is permitted. The original 45° (90° included) seat angle must be maintained.
- Standard valve stem seals must be retained.

### **20e : CAMSHAFTS AND PULLEYS**

- The only permitted camshafts are the standard production camshafts as per picture below.
- The camshafts must remain entirely unmodified. It must be fully manufactured and ground by the Ford Motor Company. It is prohibited to grind from blanks, re-grind or re-profile. Only the production surface finish is permitted. Shot peening, shot blasting, surface treatments or polishing are prohibited.
- Exhaust and inlet camshafts must not be interchanged.
- The only permitted camshaft drive pulleys are the standard Ford items.
- The cam drive pulleys may be keyed to the camshaft by dowel only.
- The sprung loaded cambelt tensioner may be locked or replaced with fixed item.

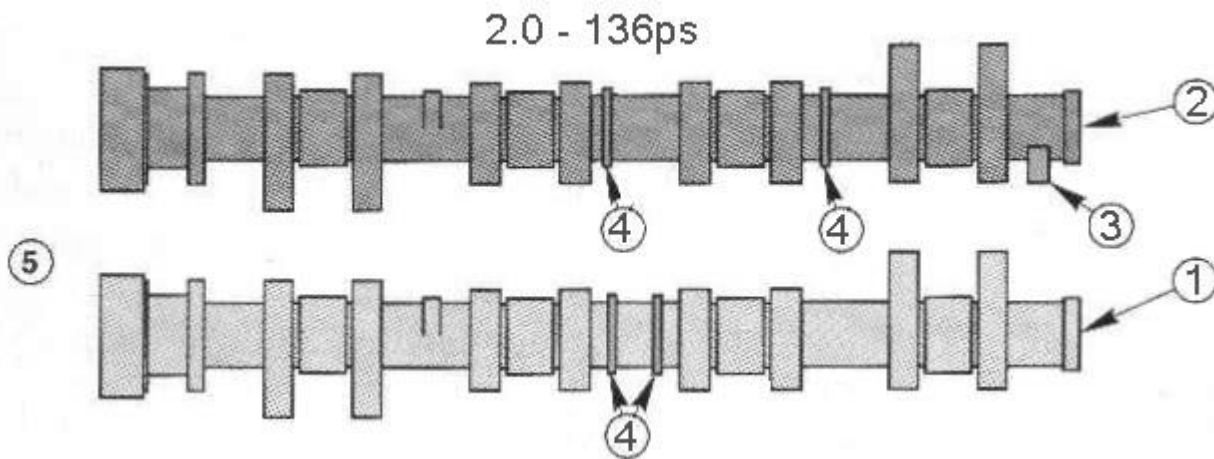

- 1 Exhaust Camshaft
- 2 Inlet Camshaft
- 3 Cam Position Reference - Inlet Camshaft
- 4 Identification Rings
- 5 Driving end (pulley end)

### **20f : CONNECTING RODS**

- Connecting rods must be standard.
- Machining/grinding is not permitted to remove metal from the connecting rod or cap.
- Polishing is prohibited.
- Connecting rod bolts are free subject to them remaining in ferrous material, the con rod may not be modified to fit bolts and the minimum weights respected.

### **20f : PISTONS**

- Pistons must be standard production pistons unmodified in any way.
- All three piston rings must be fitted as intended, piston rings must be standard production items or replacement items to Ford Motor Co. dimensions.

### **20g : CRANKSHAFT**

- A standard crankshaft must be used.
- No balancing is permitted.
- Polishing other than the 9 bearing surfaces is prohibited.
- Crankshaft journals must remain within Ford positional tolerances if a repair re-grind is carried out.
- Crankshaft pulley and damper must be retained and unmodified.
- Additional drives to water pump may use this pulley, or extra pulleys mounted in front of the crankshaft damper.
- It is not permitted to alter the number of bearings or fit bearings of less than standard production width.
- The crank journals may be re-ground for reclaim.
- Standard oversize and undersize bearings are permitted.
- A marker must be fitted which accurately aligns the crankshaft to the cylinder block at No.1 piston TDC. This marker must be visible and fully accessible to the scrutineer's without removing any component other than external bonnet panels, and without removing the engine from the car.

### **20h : FLYWHEEL AND CLUTCH**

- The mandatory steel flywheel supplied by Spedeworth may not be modified in anyway.
- Flywheel bolts are free subject to them remaining in ferrous material.
- No modifications to either crankshaft or flywheel in order to fit is permitted.
- Clutch to be standard Ford Pinto based 8.5" (8 ½") item only.
- No competition items.
- Standard Ford Pinto based starter motor must be fitted.
- Competition starter motors can be used.

### **20i ENGINE COVERS**

- The cam belt covers cannot be modified or deleted.

### **20j SUMP AND PICK UP PIPE**

- Oil sump and oil pick up pipe are free.

## **20k OIL FILTER**

- Oil filters are free but must have a secondary fixing.

## **20l OIL COOLERS**

- No oil cooler is permitted.

## **20m COOLING SYSTEM**

- A water based liquid cooling system is mandatory.
- The standard production water pump and housing must be retained, although drive to the pump, its rotational speed and direction may be changed.
- The radiator and associated pipes are free.
- No other pump may be used to circulate or assist circulation of the coolant liquid.
- Thermostat housing is free.

## **20n : ENGINE IGNITION CONTROL UNIT (ECU) AND ELECTRICAL**

- The only means of ignition will be by use of Ford crankshaft speed sensor fitted to the standard manual sensor housing and Ford based ignition coil.
- No other sensors engine or chassis permitted.
- The mandatory engine ignition control unit (ecu) and wiring loom supplied by Spedeworth will be registered to driver and electronically sealed. Neither can be modified in any way.
- The engine ignition control unit (ecu) and/or any other ignition components may be exchanged, or electronically interrogated at any time (including the time allocated for practice or testing) upon the request of a designated official from Spedeworth.
- It is prohibited to use any other method or component to trigger, distribute or time the ignition.
- The coil unit may be re-positioned
- The HT leads to the sparking plugs are free.
- Sparking plugs are free, provided they fit the engine without any modification to the cylinder head or the sparking plug and that the sparking plugs place the spark gap in the same position as the production sparking plug within the combustion chamber.
- The ECU diagnostic connector must be positioned in an accessible position, allowing the scrutineer free access to it at all times.

## **20o : INLET MANIFOLD**

- Mandatory inlet manifold supplied by Spedeworth may not be modified internally.
- Standard manifold to head casting gasket or silicone based sealer may be used to seal face to cylinder head only.
- At any point in time Spedeworth can introduce the fitment of a restrictor plate fitted between manifold and carburettor mounting plate of any given size if it is deemed suitable to reduce the output of any engine at any time before during or after any practice, testing or racing.

## **20p : CARBURETTOR**

- a) Only the standard Weber 32/36 DGV/A carburettor may be used with a maximum sized chokes of 26mm and 27mm.
- b) No polishing or re-profiling is allowed.  
No modification to the carburettor body or original design. The interchanging of the carburettor top from other Weber models is not allowed but float bowl vent & the air correction jet vent, & the idle jet vent may be modified.
- c) Gaskets must be original or replicas of original (i.e. no modified gaskets).
- d) A single original specification adapter/insulator block must be fitted between carburettor and inlet manifold, with two gaskets approximate total thickness 5mm I.E. as supplied with Gasket set.
- e) Main jets, primary and secondary jets, auxiliary venturi, and emulsion tubes may be replaced with a different size of the same part.
- f) Accelerator pump jets may be changed, but face downwards towards butterflies.
- g) Butterflies may be modified to open together, replacement spindles may be fitted with standard screws. Cold starting devices may be removed, with retaining lugs and subsequent holes blanked off.
- h) Air and fuel galleries may not be enlarged or modified; fuel may enter needle valve/float chamber from either side. Floats may not be modified or weighted, and must control the fuel flow.
- i) Needle valves may not be larger than 250, and not enlarged or modified.
- j) The power valve must be fitted in the base of the fuel bowl, but may be sealed off, and the diaphragm may be removed.
- k) No trumpets are allowed. The calibrated brass bush which controls the high speed enrichment, fitted on the secondary venturi side of the carburettor between the top and base of the carburettor, may be sealed off or enlarged, but must be fitted.

- l) A secondary fixing on the fuel feed-line is required. It is permitted to use a grub screw, or similar device, to fix the auxiliary venturi to the carburettor body.

## **20g : EXHAUST**

The exhaust manifold to be used must be the Ford Focus small four branch manifold which must remain standard, you can weld to this, making your own exhaust. The approved Simpson or Edwards exhaust may be used or any other standard silencer as long as the car is quiet, this comes down to the scrutineers discretion.

## **21. WEIGHT**

Warning : Cars can be weighed at any time before, during or after a meeting, without driver. They must always achieve the minimum weight; the adding of fuel or any other liquids is not allowed to achieve this minimum weight. The minimum car weight is 900kg. The use of ballast to achieve this weight must be either steel plate, dumbbells' or lead bolted to the floor. *For steel plate or lead this must have a minimum of two 19mm spanner head size (M12) bolts on each lot of ballast. Dumbbells must have a bolt or studding to the size of the centre hole with sufficient washers.* All weights must be bolted in the floor inside the car, not underneath or the outside of the car.

Underweight Vehicle Bans:-	Car Underweight by:	Banned From Racing For:
	0.001kg – 1.0kg	1 month
	1.001kg – 2.0kg	2 months
	2.001kg – 3.0kg	3 months
	3.001kg & over	6 months

The maximum right-side weight will be 53.5%.

- If you are checked and over the 53.5% but under 54% you will lose all points/monies due on the day and receive a final warning and loaded for the day.
- If you are found on a second occasion to be over 53.5% but under 54% you will receive a one meeting suspension from your registered promotion & cannot race anywhere until this is served, also lose all points/monies due on the day. Anyone over 54% on their first check will receive an automatic one meeting ban and loaded immediately with loss of any points or monies due (if applicable).
- If a driver is found over 54% on a second occasion the penalty will automatically be doubled, or possibly carry a longer suspension. Checks will be carried out at any time.

**The reason for the weight increasing so much is the formula needs to move on from Sierras and start going to newer cars but must be kept rear-wheel drive.**

## **22. TRANSPONDERS**

Transponders are mandatory and should be working at all times. They should be fitted 1.8 metres back from the front most position of the car. A hole of at least 6" (150mm) square is required in the floor, with the transponder fitted vertically, just below the hole. In the event of a dispute with the transponder result, the Steward of the meeting will make the final decision. Any driver found to have fitted the transponder further forward than the required 1.8 metres will be excluded up from the meeting.

## **23. RACEIVERS**

All drivers MUST use an official Raceiver.

Any driver whose Raceiver is not working when forming the grid prior to a race will not be allowed to race, unless it can be repaired before the race start.

It is strongly recommended that you carry a spare battery either in your overall pocket or taped inside your car.

## **24. SAFETY EQUIPMENT**

**Please visit the ORCi website [www.orci.co.uk](http://www.orci.co.uk) for current safety equipment regulations.**

## **25. DATA LOGGING**

- No data logging is permitted.**

## **26. MALCOLM GIRLING RULE**

The Malcolm Girling Rule may only be used on championship races which covert a roof grade e.g. World Championship. This is when a car has deliberately been taken out by breaking the rules of racing within the last 3 laps of the race e.g. a car coming off the infield to stop the leader.

If the Steward Of The Meeting decides that the Malcolm Girling has come into effect the result shall go back to when the offence occurred and the leader of the race at that point will become the winner. The Malcolm Girling rule only applies to the driver leading the race.

## **27. GRADING & START POSITIONS**

A 4 inch stripe from the front to the rear of the roof on the passenger side of the car must be in place denoting the appropriate roof grade colour. The grading strip must not have any sign-writing on it. If you win a race at a meeting; you will start the remaining races from the rear of your grade. Should you win another race at the same meeting – you will be automatically upgraded.

Multi-Champions will start next to the World Champion.

When signing in you will be issued with a grid which shows your starting position for your races, unless you are instructed differently by a race official or it is a championship event i.e Reverse grid format. Drivers are reminded that it is your responsibility to line up in the correct position on the grid this includes leaving gaps if certain cars are absent. If spotted starting in the wrong grid position before the initial green flag you will be penalized to the back of the grid. If it is brought to the steward of the meetings attention after the initial green flag you will be excluded from the result. This is subject to change depending on the promotion, drivers should confirm with the steward of the meeting beforehand which race format is being used.

***The British Championship, European Championship & National Championship will be classed as an open championship.***

***Certain promotions have started a new lining up system with in the Red/Blue grade, were the drivers in this grade will pick out of the hat at the drivers briefing for a reverse grid format amongst there grade.***

Grid Line up / Roof Order:

World	Gold
Points Champion	Silver Roof
European	Red/Yellow Chequered
British	Black/White Chequered
National	Gold Stripe with red roof
Best In Britain	Union Flag
English	St. George's Cross
Scottish	St. Andrew's Cross
Northern Irish Champion	<del>Union flag incorporating the Ulster banner</del> <b>Green/White Chequered</b>
Southern Irish Champion	Republic of Ireland (Irish Tricolour)
Red	
Blue	
Yellow	
White	

The roof of a car may display a championship status providing the driver is the reigning champion e.g. World Champion, Southern Champion. No sign writing is permitted on the roof of the car displaying previous championship history which is no longer current e.g. the 2015 National Champion cannot display the fact of this in 2017.

The following parts have to be bought from Spedeworth Fabrications 2015 Ltd.

1. Inlet Manifold
2. Flywheel
3. Ignition pack and wiring loom

From the 25<sup>th</sup> April 2020, All Zetec engines must be using the Latest spec Spedeworth flywheel & not the IKE model. Also must be on the OMEX ECU & Wiring Loom.

Northern Ireland & Ireland Registered drivers have to be changed over from 1<sup>st</sup> June 20.

These are all numbered parts, so to buy these items please call 01252 322934

### **Protest Zetec Engine Buying Price Announcement**

Spedeworth / Incarace would like to announce that the protest buying price for the Zetec engine for the Lightning Rods will be £1500 + VAT.

The buying price of the Zetec engine is the price to be paid to buy and protest another driver's engine at a race meeting. To buy the engine you have to be a licenced driver to this formula and racing at the event. The driver buying the engine can be kept anonymous.

This price does not include the inlet manifold, Carburettor, clutch and flywheel, wiring loom or the ECU.

Spedeworth / Incarace are looking to make short oval racing more affordable for drivers and to encourage more drivers into the sport and we believe that this is another way of achieving this goal.

### All Oval Racing Formulae

Permitted fuel specification from 1<sup>st</sup> January 2008 (this specification supersedes all previous specs).

1. All cars must only use fuel from roadside pumps as defined below.  
Petrol (Motor Gasoline of the type on sale to the general public from roadside filling stations) BS 4040 (Leaded) Subject to a valid permit for use. LRG (Unleaded), BS EN 228 (Unleaded), BS7800 (Super Unleaded).
2. Petrol is a product refined from crude oil that contains a large number of identifiable compounds that can typically be 250 in number. These compounds can be identified and compared to the available petrol from major oil companies and suppliers.
3. Unless otherwise stated, or the distinction is made between leaded and unleaded petrol, major gasoline fuel shall meet the following; Acceptance levels for Octane numbers will be determined at 95% confidence level. Only additives to this motor gasoline fuel solely for the purpose of lead replacement are allowed.
4. Lead Replacement Gasoline, LRG, also known as LRP. Only additives from Sodium, Phosphorous, Potassium, or Manganese according to manufacturers recommendations are allowed. Note; Manganese can enhance octane values in any petrol. Under no circumstances will values in excess of 0.005 grams/litre be permitted.

**Lead in excess of EU directive 98/70EC requirements is illegal.**

5. We reserve the right to amend the detail of the above specification to reflect any change occurring in the quality of the fuel on sale to the general public at any time.

### Roadside fuel consistency when testing fuel samples.

	<b>BS EN 228</b>	<b>BS 7800</b>	<b>BS 4040</b>	<b>LRG/LRP</b>	Test Standard
Motor Oct No (max)	89.0	89.0	89.0	89.0	ASTM D2700/86
Mon (min)	85.0	86.0	86.0	86.0	ASTM D2700/86
Research Oct No (max)	100.0	100.0	100.0	100.0	ASTM D2699/86
Ron (min)	95.0	97.0	97.0	97.0	ASTM D2699/86
Lead (max)	0.005	0.005	0.15		ASTM D3341 / IP362
Lead (min)	ASTM D3237	ASTM D3237		0.005	ASTM D3237 / D3341 / IP362
Density @ 15°	0.720 - 0.775	0.720 - 0.775	0.720 - 0.775	0.720 - 0.775	ASTM D1298/ D4052
Oxygen % max	2.7% w/w	2.7% w/w	2.7% w/w	2.7% w/w	Elemental
Nitrogen % max	0.1% w/w	0.1% w/w	0.1% w/w	0.1% w/w	ASTM D4629/ IP379
Benzene % max	1.0% v/v	1.0% v/v	1.0% v/v	1.0% v/v	EN238
Sulphur	150mg/kg	150mg/kg	150mg/kg	150mg/kg	EN ISO 14596 / ASTM D2622
Olefins*	18% v/v	18% v/v	18% v/v	18% v/v	ASTM D1319
Aromatics*	42% v/v	42% v/v	42% v/v	42% v/v	ASTM D1319

\* Olefins and Aromatics values are expressed as a percentage of total fuel.

**Please note that all of the above rules are subject to change in respect of Health & Safety requirements.**

***Drivers and teams are reminded that a secondary means of supporting a vehicle must be used when working underneath a car that has been jacked up (i.e. axle stands).***

**DRAFT RULES FOR 2022 IN BOLD/ITALIC/RED PRINT.**

**ITEMS MARKED ~~STRIKETHROUGH~~ ARE NO LONGER ALLOWED**

**2022 Lightning Rod Technical Specifications DRAFT 3, Dated 13<sup>th</sup> October 2021.**