

INCARACE

MOTORSPORT LIVE

2020 INCARODS

SPECIFICATIONS, RULES AND REGULATIONS



CONTENTS

1. CARS ELIGIBLE	2
2. PREPARATION	2
3. BODYWORK	2
4. SUSPENSION	3
5. ROLL CAGE	3
6. ENGINES	4
7. GEARBOX / DIFFERENTIAL	4
8. CARBURETTOR	4
9. INJECTION SYSTEM	5
10. FUEL SYSTEM	5
11. COOLING SYSTEM	5
12. EXHAUST SYSTEM	5
13. BATTERY & ELECTRICAL	5
14. STOP LIGHTS	5
15. BRAKES	6
16. WHEELS & TYRES	6
17. DRIVER'S SEAT	6
18. SAFETY EQUIPMENT	9
19. RACING NUMBERS	9
20. GRIDS	10
21. WEIGHT	10
22. DRIVERS ELIGIBLE	10
23. RACECEIVERS	10
24. ROOF COLOURS	11
25. FLAGS/SIGNALS	11

INTRODUCTION

This formula is designed primarily for those drivers who wish to compete in Oval Racing without the substantial financial investment or high level of commitment of our other present formulas. **Drivers who have raced in any other senior formula may compete but generally must not have reached higher than Yellow grade. All licence applications will be reviewed by the Promoter and it must be understood that applications may be refused if it is considered that the prospective driver is too experienced for this entry level formula.**

INCARODS feature low cost, well turned out cars competing on a STRICTLY NON-CONTACT basis.

VIOLATIONS

When referring to the engine, gearbox, differential, mechanical or construction, rules and regulations the principle will always be: Unless permission is specifically granted to make modifications, or any variation, nothing may be done to alter or change in any way the standard Parts.

Unless these rules state you can do it, you CANNOT DO IT.

Cars, Engines and Fuel will be checked on a random basis and all drivers must be prepared to have their engine stripped for examination at any time. If the driver does not have the expertise to do it, then he/she must provide someone to do it for them. Refusal to allow the engine strip may result in a ban of up to one year from all formulas.

Violations will result in an immediate suspension of all racing facilities and any refusal will also result in an immediate suspension.

All car and engine specifications will be taken from the Technical Service Data book for cars as published by Glass's Guide Service Limited.

It is the driver's responsibility to check the legality of his or her own car prior to competing.

NB: Drivers are reminded that scrutineering checks can be carried out at any time and most certainly on all official Championships. If parts are suspected of being illegal, make sure you leave them with the promotion if you do not agree. If you refuse it will automatically make the parts illegal. It is the responsibility of the driver to prove to the promotion that the part is legal by the way of written proof of where the part originated. This must be done within 7 days, otherwise the part(s) in question will be deemed to be illegal and will result in immediate suspension from racing and referral for disciplinary action.

SCRUTINEERING

Arrival at the Raceway is required minimum 1 hour before the advertised start time to allow scrutineering to be carried out. You need to present your car to the scrutineering area to be checked, as soon as possible after arriving at the raceway. The driver must accompany the car, complete with racing overalls, crash helmet, race suit and race licence.

1. CARS ELIGIBLE

Any front wheel drive, single carburettor, or single point injection, maximum 4 cylinder saloon, hatchback or coupe car with a steel body, not exceeding 1600cc are allowed. No Toyota Starlets or Honda Civics are allowed. No Turbos or Superchargers allowed. Please note, in all cases, Estate cars or Vans are not allowed. Cars with competition type engines are not allowed, e.g. Mini Coopers, Lotus Sunbeam, Cosworth. No Ford RS Parts allowed whatsoever. Injected cars may be converted to conventional carburation if available in that manufacturers model range. Single point injection may be used.– if in doubt, please ring the Incarace office to check. ***Ford Escort cars will no longer be permitted from the 1st January 2022. Multi-point injection is being considered to be including in the 2021 rules. Drivers who wish to run multi-point injection may do so as experimental from the rear of the grid (non-point scoring) during the 2020 season.***

2. PREPARATION

- ◆ Remove all exterior mouldings/headlamps/door handles.
- ◆ Remove all glass, interior trim, dashboard, head linings, door linings, floor coverings, passenger seats.
- ◆ All window mechanisms must be removed.
- ◆ It is recommended that all obsolete wiring be removed.
- ◆ Remove spare wheel carriers and tow bars if fitted.
- ◆ Grilles must not be removed. No replacement, "home-made" grilles allowed.

3. BODYWORK

- ◆ All panels must remain as standard (or steel pattern types) no home made panels, i.e. fibreglass, plastic or similar replicas. Door inners may be removed. Removal of structural stiffeners is not permitted, with the exception of boot and bonnet.
- ◆ All doors and tailgate must be secured shut. They may be tack welded (1" in 4") or bolted shut not by tying, chaining or taping etc.
- ◆ Passenger doors may not be folded down.

- ◆ Standard external door mirrors are permitted on either/both sides. For safety, the glass must be taped to the housing. **After market mirrors are permitted.**
- ◆ Mirrors may be fitted inside.
- ◆ A hole may be cut in the bonnet near to the carburettor, maximum size 6" square.
- ◆ Bonnets may be secured with up to 4 bonnet pins, (2 front, 2 back). The pins shall be ½" (12mm) maximum diameter and 1½" long maximum above the bonnet. These bolts must not pass through the chassis or attached to the suspension bed. Front bolts must go through the slam panel or the inner wings. Front bolts must be no further forward than the slam panel. Maximum size of washer is 1½" x 1½" x ¼".
- ◆ Triangular corner plates may be fitted between the wing top and scuttle maximum size 120mm x 1mm thick.
- ◆ Where bonnet slam panels are replaced, lightweight tube or box (2" x 1" or 1" x 1" with 1mm or 1.5mm wall) must be used. Cross ties must be 16- 18 gauge, 1mm wall box section. Panels must not be doubled. Where headlamp apertures are filled, they must not have more than a 1" overlap.
- ◆ Additional gussets must not be added to provide strength to chassis legs etc.
- ◆ Headlight and tail light apertures may be filled in with aluminium **BUT NOT STEEL**, maximum 1 mm thick and maximum overlap of 1" and if fitted must either be pop riveted or self tapping screws may be used but not tack welded.
- ◆ Sun roof apertures must be plated over (riveted or welded)
- ◆ No Stainless Steel or foam filled panels
- ◆ Sun roof apertures must be plated over (riveted or welded)
- ◆ No roof spoilers or aerofoils allowed.
- ◆ Boot spoilers may be fitted if standard to the car.
- ◆ Standard bumpers as fitted to the model only. No home-made bumpers of box section, angle iron etc. In view of this being a NON-CONTACT formula, bumpers may be removed altogether provided that the Scrutineer is satisfied that the car looks neat and tidy. On later cars where the larger bumper mouldings dominate the overall appearance, e.g. Mk2 Astra, bumpers should be left on to avoid Banger like appearance.
- ◆ All holes in the front bulkhead must be filled to provide a firewall between the engine and driver.
- ◆ No welding for strength.
- ◆ No armouring.
- ◆ Bright colours for bodywork is requested and a good overall appearance is a MUST but no team colours permitted. Cars may be sign-written.
- ◆ The drivers name must appear on the sun visor and be of professional appearance. The sun visor must be made of aluminium with a maximum depth of 4".
- ◆ A metal upright ¾" x ¾" must be welded or bolted into the windscreen aperture, one third of the way along the driver's side.
- ◆ The word" INCAROD" must appear on the rear nearside corner of the car.
- ◆ ~~The roof shall be painted according to the driver grading and at least one flashing amber light fitted for Superstars.~~
- ◆ **Superstar grade drivers must have at least one flashing amber light fitted to the roof of the car.**

SCRUTINEERS WILL FAIL CARS THAT ARE NOT IN A CLEAN & TIDY CONDITION

4. SUSPENSION

- ◆ Any standard spring (or non-competition after-market eg Monroe).
- ◆ These may be cut or heated to lower.
- ◆ No ADJUSTABLE springs or shock absorbers permitted.
- ◆ No after-market competition type springs or shock absorbers (eg Koni, Spax, etc)
- ◆ Coil springs must retain the original overall diameter.
- ◆ Coil springs may be retained by either wiring, tie wraps or clips, but not welding.
- ◆ All suspension pickup points and suspension parts must remain standard and must not be modified, however a tolerance of ½" between the nearside and offside wheelbase measurements will be allowed for accident damage.
- ◆ You must run bump stops, but these must be run on both sides and must be symmetrical and the same size.

5. ROLL CAGE

- ◆ No Alloy roll cage or part cages are allowed.
- ◆ The minimum steel roll cage protection you must have is one front hoop, one rear hoop, two roof connecting bars, one dash cross bar, two N/S chicken bars and two O/S chicken bars
- ◆ Drivers door bars must be two continuous bars constructed of cage material (38mm x 2.5mm) or (32mm x 3mm) with a minimum of 2 connecting braces made of cage material also. All other bracing is free. Passenger side may either be the same as listed above or a cross formation, i.e. one continuous bar from hoop to front leg with two connecting bars forming a cross. This cross must go from waist of the vehicle to the bottom of the hoop so as to fill the door aperture.

- ◆ The roll cage hoop feet must be on four welded 23cm square plate 3mm (min.) thick, or a piece of 38 x 38 mm box section, 2.5mm minimum thickness, connecting front and rear hoop feet welded to sill or floor.
- ◆ All joints must be welded over 90% of the joint unless professional clamps are used.
- ◆ The cage must not protrude through the bulkhead.
- ◆ Rear cage bars must terminate at least 4" from the rear panel.
- ◆ All bars connected to the cage must be steel.
- ◆ The minimum thickness of the roll cage are 1¼" OD 10swg (3mm) tube 1½" OD 12swg (2.5mm) tube 1½" x 1½" 10swg (3mm) box iron.
- ◆ You are now allowed to independently brace from the top of the front suspension turrets back to the roll cage. The maximum size for this bracing is roll cage specification.
- ◆ Please note that this is intended purely to save your car from extensive damage to the chassis and whilst this is rearward of the front wheels any car that is built beyond the spirit of this rule and could be considered as armouring in any way, will simply not be allowed to race.

6. ENGINES

- ◆ Only 2 valves per cylinder allowed.
- ◆ The engine type must remain standard to the make of car used, e.g. Vauxhall must be Vauxhall. In addition, any interchanging of engines from another model must not increase the cc size of what was manufactured within that model. I.e. Any Vauxhall engine compliant within these rules may be fitted into a Vauxhall car, compliant within these rules, as long as that cc range was manufactured in that model.
- ◆ Where engines have been converted from injection to carburettor an adapter plate may be used to allow correct fitment of carburettor manifold to the head. ***This must be a maximum thickness of 30mm and the port hole must stay the same size as the cylinder head and must not be funnelled in any way.*** The only carburettor allowed in these cases is the Solex Z2 twin choke (as in AXGT)
- ◆ A Ford KA, Focus or PUMA must be fitted with the Ford 1600cc CVH engine – No other engine is allowed in these cars
- ◆ A Ford Fiesta, Escort or Orion may also use the Ford 1600cc CVH or alternatively be fitted with the Ford 1600cc OHV engine.
- ◆ A 1.5mm overbore is allowed.
- ◆ All parts must remain as manufactured within the engine type used such that the compression ratio remains standard to that engine type – i.e. the cylinder head and block must originate from the same cc of engine.
- ◆ Pistons must be standard – no modifications. Pistons and rings may be size matched with the appropriate overbore as specified above.
- ◆ Flywheels must be standard – no lightening allowed.
- ◆ Only a standard camshaft to the engine is allowed, or a replacement item with the same geometry (lift, duration etc)
- ◆ The inlet and exhaust manifolds must be standard to the engine. These may be de-carbonised but not highly polished or ported i.e. No removal of casting marks etc.
- ◆ Sumps may be baffled to prevent oil wash away from oil pick up point.
- ◆ Air filters are free.
- ◆ Alternators may be removed.
- ◆ The engine must be fitted with a metal catch tank of 1 litre minimum capacity connected to the engine breather system.
- ◆ ***All engines must have drilled holes in the studs for the exhaust manifold and inlet manifold to allow the engines to be sealed.***
- ◆ ***For the 2020 season we are introducing a buying price of engines. This price will be £600 inc. VAT. Only a registered (full 2020 licence) Incarod driver racing at the event can buy the engine. This does not include the carburettor, manifold, flywheel or clutch. The driver buying the engine can be kept anonymous.***

DRIVERS MUST BE REMINDED THAT ALL ENGINE PARTS MUST REMAIN STANDARD OR AFTER-MARKET

7. GEARBOX/DIFFERENTIAL

- ◆ Gearbox must be as manufactured to the same model of vehicle, i.e. you cannot exchange a four speed gearbox onto an engine manufactured only with a five speed gearbox, or vice-versa, however you may fit a Ford Diesel gearbox to the Ford PUMA to allow easier fitment to the CVH engine.
- ◆ Axle and ratio must be as manufactured.
- ◆ No locked differentials or limited slip differentials are allowed.

8. CARBURETTOR

- ◆ Choke sizes must remain standard to the vehicle, however a Ford engine may use up to 24mm/25mm maximum choke size when using a Weber conversion.
- ◆ Must remain standard to the manufacturers model range.
- ◆ Cold Start devices may be removed.
- ◆ Re-jetting is permitted

9. INJECTION SYSTEM

- ◆ Single Point injection is allowed but must be used in conjunction with a competition type pump eg FACET.

10. FUEL SYSTEM

- ◆ Electric fuel pumps may be fitted.
- ◆ The original petrol tank must be removed.
- ◆ Flexible non-metallic fuel lines may be used to connect metal fuel pipes to carburettor and fuel tank. In all cases, fuel lines shall be securely clipped to prevent damage (or being tripped over etc).
- ◆ Only road-side fuel is permitted. (Unleaded, 4 star or LRP). No AVGAS (aviation fuel). Special mixes or Methanol blends, Nitrous Oxide or octane boosters are not permitted.
- ◆ Only tanks with a maximum capacity of 4 gallons or less are permitted. These must be fitted rear of the driver but in front of the rear axle centre line,. They **MUST NOT BE FITTED BELOW THE CHASSIS RAILS** of the car, and the floor must not be cut in any way to accept the tank. All tank filler caps must be of a secure leak proof metal or screw fitting. Petrol pipes must be of metal or metal covered and have a shut off tap within easy reach of the driver. All tanks must be fitted with a breather system which prevents spillage if a car is inverted **e.g. a one-way valve**. All petrol pick up pipes must draw through a stand pipe from the top of the fuel tank. Four 2" holes must be drilled at the lowest point under tanks to allow spilled petrol to drain. A firewall between fuel tank including filler cap/pump and driver must be fitted.

11. COOLING SYSTEM

- ◆ Radiator must be fitted in original position.
- ◆ No steam tanks allowed.
- ◆ Thermostat may be removed.
- ◆ No heater matrix permitted inside the car. If retained, the original matrix must be relocated under the bonnet.
- ◆ No other oil or water coolers permitted.

12. EXHAUST SYSTEM

- ◆ No car will be allowed to race without an exhaust system, which must be fitted underneath the car.
- ◆ The down-pipe must be standard but the rest of the system is free and must be suitably silenced.
- ◆ The system must terminate behind the centre line of the rear axle.
- ◆ All drivers must be aware that if your car is above the required noise level you will not be allowed to race. The Stewards decision is final.

13. BATTERY AND ELECTRICAL

- ◆ Batteries must be securely clamped in place and covered with a leak proof material to prevent spillage of acid. They may be fitted under bonnet, in passenger footwell or behind the driver, but the floor cannot be cut to accommodate them. They must be fitted at least 6" from the fuel tank.
- ◆ An electrical cut/off switch must be fitted to the R/N/S corner of the car, **have an Electricity Danger Decal & this switch when turned off must kill all power to the car.**
- ◆ If the car is fitted with an electrical fuel pump, a switch must also be within easy reach of the driver.
- ◆ Self-starter motors must be fitted and in working order at all times.
- ◆ The use of a rev counter is permitted.
- ◆ A 24 volt starter system is permitted.
- ◆ Electrical wiring and petrol pipes must not be run side by side ie. When running parallel through the car interior. They should take separate routes as far away from each other as possible but as a minimum 12" apart.

14. STOP LIGHTS

- ◆ Either two stop/brake lights or one single stop/brake strip-light must be fitted onto the rear parcel shelf hung from the roof. If two lights, they must be a minimum of 30 inches (762 mm) apart facing rearward. Lamp(s) must be operated by the standard stop light switch as fitted to the particular model of car. No other switches or modifications to switches to be made. Bulbs to be of 21 watt intensity
- ◆ For round type lamps: minimum 3", maximum diameter 4"
- ◆ For square type lamps: minimum 3" square maximum 4" square.
- ◆ For strip type lamps 16" (406mm) maximum width.

15. BRAKES

- ◆ Must remain as manufactured and working on all four wheels.
- ◆ The handbrake must be in working order.

16. WHEELS & TYRES

- ◆ Any standard road wheel to a maximum diameter of 14" all wheels must be of the same offset and must fit completely under the bodywork.
- ◆ Any size standard road wheel to the manufacturers range may be used, however the same size wheels and series of tyre must be used on the same axle.
- ◆ Hub caps and wheel trims must be removed.
- ◆ All balance weights must be removed.
- ◆ Tyres can have a maximum diameter of 185mm, minimum **55 series**
- ◆ Any tyre with buffed markings will not be accepted.
- ◆ The only tyres allowed are the TOYO CF1, TOYO CF2 & **Uniroyal Rain sport 3.**
- ◆ **The TOYO CF1 & TOYO CF2 are NOT permitted after the 31st July 2020. From the 1st August 2020 all cars must be using the Uniroyal Rain Expert 3 tyre.**

Note: The promotion reserves the right to review the regulation relating to wheels and tyres at any time.

17. DRIVER'S SEAT

- ◆ ~~A seat with a head restraint must be fitted. The seat must be securely mounted at shoulder height to the cross bar or to the rollover bar and bolted securely to floor.~~

- ◆ **You must have a Competition type Driving Seat with a head restraint.**
- ◆ **The seat should occupy its original position where possible and be suitably supported at shoulder height and on both of the sides and back, with a suitable framework or seat stiffener's.**
- ◆ **If the seat sits behind the b/pillar hoop a secondary support to the cage must be added. An example of this is shown in the diagrams within this section of the document. If the modification goes to the floor it must be sat on 23cm square plate 3mm (min.) thick.**
- ◆ **This new section must not be constructed in a way that a drivers helmet can make contact with it.**
- ◆ **Material od and thickness as rest of roll cage.**

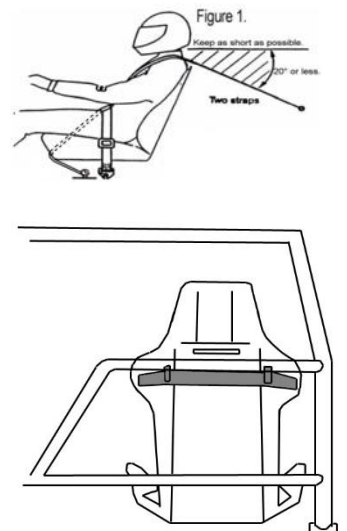

FRONT VIEW

SECONDARY SEAT SUPPORT BARS



REAR VIEW

SECONDARY SEAT SUPPORT BARS



18. SAFETY EQUIPMENT

- ◆ Helmets must be of a minimum standard as directed by British Oval Racing Safety Executive (B.O.R.S.E). These are FIA8860-2004, FIA8860-2010, Snell SA2005, Snell SA2010, Snell SA2015, SFI Foundation 31.1A, SFI Foundation 31.2A. The E2205 European standard helmet may be used in Fibreglass, Carbon or Tri-Composite form only i.e. NO POLYCARBONATE helmets are allowed. It is important that the helmet fits the driver correctly. Shatterproof goggles/visors must be worn although tinted visors are not advisable. ~~Your~~ helmet must display the current ORCi (ORC15) sticker. All helmets MUST display a new green "ORC20 Approved" serial numbered helmet sticker, as per Illustration 01. Older blue 2015, and red 2010 stickers are NOT valid (Illustrations 02 and 03).



Illustration 01



Illustration 02



Illustration 03

(Note: A programme of re-validation and issuing of the new green stickers will be undertaken by ORCi appointed officials during the 2020 season. This programme will take some time to implement, and therefore the blue ORC15 Approved sticker will remain temporarily accepted until the programme has been completed. Helmets to the SA2005 and FIA 8860-2004 standards must NOT be used/presented, as they are no longer permitted.)

- ◆ Neck braces are recommended.
- ◆ Fireproof balaclavas are **MANDATORY** and must be marked appropriately.
- ◆ Fire retardant gloves are **MANDATORY** and must be marked appropriately.
- ◆ A minimum of 3" (75mm) wide safety belts (1.75" (40mm) sub-strap) are mandatory. This must be a full five point buckle release harness (including NASCAR type) with sub-strap and must be fitted and bolted to the floor and/or the roll cage. Shoulder belts with a sternum protection latch are highly recommended. The sub-strap must be used at all times and all belts must connect to the quick release buckle. In the case of NASCAR lever latch buckles it is advisable to fit a secondary means of detent to prevent overall sleeves accidentally unhooking buckles during racing. A small section of Tubegrip elasticated bandage slid over the hooked buckle serves this purpose. Special attention must be paid to the condition of seat belts and fixings once fitted. An extra bar is to be fitted to roll cage behind drivers seat approx 4" below shoulder height of driver. Your seat belts may be fixed to this bar. The bar is to be of roll cage material specification.
- ◆ Drivers must wear racing overall type clothing of flame retardant Proban or a high specification material and this must be maintained in a clean and tidy condition in view of the public. N.B. If wet weather clothing is used this must be worn IN ADDITION TO and NOT INSTEAD OF the regulation flame retardant overall type of clothing described above.
- ◆ A quick release cloth window net must be fitted to the driver's door window aperture. The netting should have holes not larger than 7.5cm or 3" wide. It should come down level with the steering wheel, and should be flexible and easily removable separate to the movement of the door.
- ◆ A 1Kg Dry Powder Gauge Fire Extinguisher is highly recommended and if fitted, this should be in a tube with a spring top and should be within easy reach of the driver. Old type BCF (green) type extinguishers are not allowed. **All tow vehicles, must carry a minimum of a 2kg fire extinguisher dry powder or gas, which must be within easy reach of the driver and mechanics at all times, especially when refueling.**

19. RACING NUMBERS

FIN PLATES.

1. **Fin plates MUST be fitted from the 1st May 2020 above the roof line but they should not be larger than 305mm or 12" by 559mm or 22" wide.**
2. **Fin plate numbers must be 229mm or 9" high by 38mm or 1½" in width.**

DOOR NUMBERS

1. **The drivers racing number must appear on both sides of the car. The numbers should be 300mm or 12" high x 50mm or 2" wide, on a contrasting background, which must extend a minimum of 50mm or 2" beyond the numbers.**

20. GRIDS.

When signing in you will be issued with a grid which shows your starting position for your races, unless you are instructed differently by a race official or it is a Championship event eg a reverse grid format.

Drivers are reminded that it is your responsibility to line up in the correct position on the grid which includes leaving gaps if certain cars are absent. If spotted starting in the wrong grid position before the initial green flag you will be penalized to the back of the grid. If it is brought to the Steward of the Meetings attention after the initial green flag you will be excluded from the result. This is subject to change depending on the Promotion, drivers should confirm with the Steward of the Meeting beforehand which race format is being used.

If you win a race at a meeting; you will start the remaining races from the rear of your grade. Should you win another race at the same meeting – you will be automatically upgraded.

21. WEIGHT

Warning: Cars can be weighed at any time before, during or after a meeting, without driver. They must always achieve the minimum weight; the adding of fuel or any other liquids is not allowed to achieve this minimum weight. *The minimum car weight is 750 Kg.* Weight must be even front to rear on flat of the floor; more can be on nearside to achieve inside weight. *All weights exclude the driver.*

Underweight Vehicle Bans	
Car Underweight by:	Banned From Racing For:
0.001kg – 1.0kg	1 month
1.001kg – 2.0kg	2 months
2.001kg – 3.0kg	3 months
3.001kg & over	6 months

The use of ballast to achieve this weight must be steel plate bolted to the floor and the bolts must be welded.

The right hand driver's side weight must be a maximum 52%, at any time – this will be weighed without the driver in the car.

The following penalties apply if your car contravenes the weight rule above:

- ✓ If you are checked and over the 52% but under 52.5% on your first offence you will lose all points/monies due on the day and receive a final warning. You must have this written in your log book.
- ✓ If you are found on a second occasion to be over 52% but under 52.5% you will receive a one month suspension, lose all points/monies due on the day.
- ✓ Anyone over 52.5% on their first check will receive an automatic one month ban, and loaded immediately with loss of any points or monies due (if applicable).
- ✓ If a driver is found over 52.5% on a second occasion the penalty will automatically be doubled, or possibly carry a longer suspension. Checks will be carried out at any time.

22. DRIVERS ELIGIBLE

- ◆ Each driver is only permitted one car per meeting in Incarods and each car is only permitted one driver per meeting.

23. RACECEIVERS

All drivers MUST use an official Raceceiver.

Any driver whose Raceceiver is not working when forming the grid prior to a race will not be allowed to race, unless it can be repaired before the race start.

It is strongly recommended that you carry a spare battery either in your overall pocket or taped inside your car.

It is against the Rules to use any other radio transmitters than the official Raceceiver system. Any form of two-way radio transmission is not allowed and will invoke an automatic driver ban.

24. ROOF GRADES

Effective from the 1st May 2020 Incarace roof grades are to be displayed via car roof fins and not the roof itself.

The fins must be as follows:-

- *White Grade – Black numbers on White background*
- *Yellow Grade – Black numbers on Yellow background*
- *Blue Grade – White numbers on Dark Blue background*
- *Red Grade – White numbers on Red background*
- *Points Champion – Black numbers on silver background*
- *National Champion – Black numbers on a silver background with two gold stripes*

The rear of the fin plate must be plain and white in colour.

25. FLAGS/SIGNALS

This is to remind drivers of the flag signals as used by the Starting Marshall and Safety Marshalls on track.

- *Waved Green Flag – Go, the race has started.*
- *Waved Red Flag – Stop racing slow down & stop.*
- *Chequered Flag – Race winner has crossed the line, continue to race until the Red Flag is shown.*
- *Held Yellow Flag – Beware, you are approaching a hazard on the track, continue to race.*
- *Waved Yellow – Slow down rolling lap speed, hold your position, and do not overtake any other cars.*
- *Waved Blue Flag – Shown to a driver who must hold his racing line. Driver must either hold a line on the inner part of the track or the outer part of the track, not weave between both.*
- *Blue & White Flag – Give up your track position, you have not taken notice of the Blue flags.*
- *White Flag with a Blue spot – Oil / debris on the track.*
- *Waved Black Flag - You are disqualified, pull off the track immediately.*
- *Black cross on a White board – You may have committed an infringement and may be penalised in the results.*
- *White Flag with a Red Cross – Technical Disqualification, leave the track immediately*

For further information contact :

**INCARACE Limited
Spedeworth House
Hollybush Industrial Park
Hollybush Lane
Aldershot
Hants
GU11 PX**

**Tel : 01252 322 920
e-mail : info@incarace.co.uk**

**Booking Line : 01252 322 920
E-mail Booking : bookin@incarace.co.uk**

**REVISED RULES FOR 2020 IN BOLD/ITALIC PRINT
ITEMS MARKED ~~STRIKETHROUGH~~ ARE NO LONGER ALLOWED
[2020 Incarod Technical Specifications, Issue 4, Dated 11/03/2020](#)**