



## 2012 Specifications, Rules & Regulations

### 2.0 Litre Hot Rods

#### Contents

1. DEFINITION .....	2
2. TYPE OF CAR.....	2
3. BODYWORK / SPACE FRAME.....	3
4. ENGINE .....	5
5. SAFETY EQUIPMENT.....	7
6. PERSONAL SAFETY .....	9
7. ROLL CAGE .....	9
8. ENGINE POSITION.....	9
9. GEARBOX & FINAL DRIVE.....	10
10. OIL COOLERS .....	10
11. VEHICLE WEIGHT & BALLAST .....	10
12. BRAKES .....	10
13. AEROFOIL/REAR WING & ROOF SPOILER.....	11
14. WHEELS & TYRES .....	11
15. EXHAUST SYSTEMS.....	11
16. COOLING SYSTEMS .....	11
17. LIFTING EYES .....	11
18. WINDSCREENS/GLASS.....	11
19. STOP LIGHTS.....	12
20. MIRRORS/GLASS.....	12
21. OIL CATCH TANK.....	12
22. BATTERIES & ELECTRICAL SYSTEM.....	12
23. FUEL TANKS & SYSTEM.....	12
24. RACING NUMBERS & DRIVERS' NAME.....	13
25. ROOF GRADING.....	13
26. FINAL PREPARATIONS & COLOURS.....	13
27. SCRUTINEERING OF NEW CARS.....	13
28. TRANSPONDERS.....	14
29. VIOLATIONS .....	14
30. ENGINE SEALING .....	14
31. RULE CHANGES .....	14
32. FUEL SPECIFICATION.....	15

## 1. DEFINITION

Racing is in a clockwise direction. The object is to complete the specified number of laps in the shortest time. Baulking, pushing, or spinning another car is not permitted. The circuit is clearly marked and you are not permitted to allow your wheels to pass over the demarcation line.

## 2. TYPE OF CAR



**A.** Any four-seater, front-engined, saloon or hatchback, constructed of steel, the overall length must not exceed 3988mm (157") and the overall width must not exceed 1702mm (67") when ready to race. Consideration will be given to any modern vehicle which falls outside these specified measurements in its original form, but can comply when prepared for racing, as follows:

**Length:** By reducing the depth of either the front or rear bumper.

**Width:** On many cars, the wheel arches are the widest part of the original vehicle, and once the car has been lowered, and the wings reduced to accept the permitted wheels and tyres, the vehicle may be able to conform to the maximum width permitted. If this is the case, permission may be granted. Details should be submitted to Spedeworth for approval.

**B.** Coupes are not permitted (except as authorised by Spedeworth — drivers wishing to use a Coupe must apply to our Head Office).

**NB:** The Vauxhall Tigra, new Clio with plastic front wings (see G below), Peugeot 206cc and Ford Puma have been authorised for use, but must conform to 2LHR.2 A. above).

**C.** Bodies must remain standard, with the exception of bonnet and boot lids/tailgates, which **may** be replaced with fibre-glass only. The passenger door may be made from steel, fibre-glass, or Kevlar. The driver's side door may be either steel or Kevlar only. Panels must be replicas of the original, if replaced. The full silhouette of both front doors must be visible, i.e. the doors must not be shortened, or door sill must not protrude into door silhouette. The rear window aperture on a Vauxhall Tigra (which is viewed from the side elevation only) may be filled with metal or fibre-glass.

**D.** Independent rear wheel drive is **not** permitted.

**E.** If a body shell originally had a top and bottom wishbone front suspension, it can be changed to MacPherson Strut type suspension and vice versa.

**F.** All cars **must** be rear wheel drive. Front wheel drive cars may be converted to rear wheel drive within these Rules.

**G.** The Renault Clio produced with plastic front wings may duplicate fibre glass replicas which may incorporate the wheel arch.

**H.** Body shells must retain their original silhouette.

I. When reference is made to metal, this means aluminium may be used, but steel may not.

### 3. BODYWORK / SPACE FRAME

#### Front & Rear Wheel Drive Shells

a. Non-spaceframe cars; may be modified to accept any suspension configuration and you may build sub frames front or rear. Material (minimum thickness 2.00mm) cross bracing may be of any size and gauge. No part of the front or rear subframe can be less than 102mm (4") from the contact area of the bumper. All other aspects of these rules must be implemented.

b. A full spaceframe is permitted and must comply with all aspects of these rules (including rollcage specification). The minimum required front tubes will be 2 x 38 x 2.0mm minimum either side of the engine block, four in total, going 10"/254mm past the axle centre line with one cross member 1 x 38 x 2.0mm minimum, joining two of the front tubes 10"/254mm past the axle centre line. It will be the same for the rear with 2 x 38 x 1.5mm min gauge tubes, four in total, plus one cross member. 1 x 38 x 1.5mm min joining two of the rear tubes 10"/254mm past the axle centre line. If the spaceframe has two bars from the top of the rear roll hoop going a minimum of 10"/254mm past the axle centre line, connected to rear spaceframe, these will be classed as two of the four tubes required.

**IMPORTANT NOTE:** The January 2006 Spaceframe rule; 'any car with less than 2.0mm front spaceframe tube will have until January 2006 to rectify their spaceframe' has been amended and now reads a minimum of 1.5mm.

#### Front Wings

Front wings may be fixed to tubing when inner wings are removed.

#### Bulkhead/Firewall

May be modified to allow re-position of engine, and allow access of turret and front subframe/spaceframe supports from roll cage, exhaust, and ancillaries, but must be fabricated in steel to re-establish a complete firewall.

#### Rear Floor/Boot

a. Rear floor and rear chassis rails, and rear wheel arches, may be removed from the centre pillar, or B-Pillars to the rear panel. When rear floor is removed (in part or whole), cars must be fitted with a fully enclosed and effective rear firewall. The firewall must be constructed of metal and must not protrude into rear window aperture.

b. Covering the underside of vehicle with flooring/under-trays is not permitted.

#### Floor/Sump Guard

a. May be modified to accept gearbox and prop-shaft tunnels, which must be fabricated in mild steel. A minimum of 25mm of the original floor, connected to the inner sill between the A & B pillars, must be left on both sides of the car, and the floor must be replaced with steel. Complete drivers side of the floor from front to back must be a minimum of 1.5mm thick. The rebate lip which attaches the floor to the sill may be flattened or removed. The floor must be complete, and must not be raised or lowered by more than 25mm from its original position, which may be taken from the highest point between the A & B pillars, but do not include cross-member or seat supports.

b. Any type of flooring/under-tray, or aerodynamic aid, from the front panel to the bulkhead is not permitted. However, a sump guard may be fitted, but must not overlap the width and length of the sump by more than 76mm (3"), and must be aluminium, no thicker than 5mm.

#### Front Suspension

Any suspension configuration is permitted

a. Anti-roll bars and mounting are free.

b. With wheels and tyres, the front track must not exceed 1651mm (65"); this will be measured at the bottom of wheel rim, aluminium wheel spacers are permitted.

#### Steering

Cars fitted with a steering box as standard may convert to rack and pinion. All cars must use a standard production steering rack casing (specials are not permitted). Interchange of gears is permitted within the standard casing, which may be modified, or you may use a standard rack with a quickener fitted in the column.

#### Rear Suspension

a. A Ford Escort axle casing must be used with original ford escort shafts. Wheels and tyres must not have a rear track wider than 1651mm (65").

b. Axle measurement, without shafts, must not exceed 1232mm (48.5"), with shafts 1359mm (53.5") .

c. Anti-roll bar and mountings are free.

d. Any configuration of suspension links is permitted.

e. Aluminium wheel spacers are permitted.

f. It is not permitted to fit any type of adaptor to the axle or shafts, with the exception of aluminium wheel spacers.

g. The Bird Cage (or similar) system that allows the axle casing to rotate in its mounting brackets is not permitted. All axle mountings must be welded or bolted.

### **Suspension Joint (Front & Rear)**

- a. May be rubber-bushed or rose-jointed.
- b. All rod ends/rose joints must be steel.
- c. All suspension arms and link arms must be steel.

### **Shock Absorbers (Front & Rear)**

- a) A total of four shock absorbers may be used, one per corner.
- b) Adjustable type may be used.
- c) Adjustable spring platform may be fitted.
- d) Any readily available shock absorber with a purchase price **not exceeding £125 + VAT may be used. There will be, however, provision for any licensed 2 Litre Hot Rod Driver to purchase the shock absorbers from a fellow competitor's car for a price of £162.75 including VAT per unit.**
- e) Shock absorbers must be as from the manufacturer, ie; Gaz shocker must remain with Gaz components incl oil, No interchanging of parts or oil.
- f) Quantum shock absorbers will be banned from January 1<sup>st</sup> 2013 as they are now outside of the price range. This date has been chosen to give drivers a 12 month run-out period.**

### **Springs**

Competition springs may be used.

### **Wheelbase**

Wheelbase must remain standard,  $\pm$  50mm offside and nearside. **NB:** There is no wheelbase tolerance taken into account on engine position so you will need to check this.

### **Bodywork**

To be kept tidy and of a professional appearance at all times. No armouring or reinforcing. No sharp or jagged edges. The removal of inner pillars and inner roof skins from the body waist-line up is not permitted. All internal/replacement panels, i.e. inner wings, floor, etc., must be no thicker than the original manufacturer's item. These must have a 50mm diameter hole cut into them for scrutineering purposes. External panels, i.e. wings, spats, skirts, front and rear panels, must not exceed 1mm thick mild steel.

### **Front / Rear Bumper**

- a. Original plastic bumpers may be used.
- b. Original steel bumpers must be replaced.
- c. A fibre-glass/Kevlar replica must be used (if not available for your vehicle, you may use one from other available models). The bumper should be constructed of two layers of fibre-glass and one layer of Kevlar (minimum thickness 5mm).
- d. Splitters or bibs may be incorporated into the front bumper mould, and must not be a detachable item.
- e. The splitter or bib must not protrude forward of the contact surface of the bumper.
- f. Bumpers may be made in sections, if required, to save replacement of the complete unit if damaged.
- g. The bumper must be mounted in its original position. For those vehicles that have to use a non-original bumper, it must be mounted as close as possible to the original position, and will be at the Scrutineer's discretion.

### **Bumper Fixings**

- a. Additional means of securing the bumper is permitted, but armouring or reinforcing is not.
  - b. All bumper fixings to chassis must be via separate brackets or sleeved tubes, and must not be welded or bolted directly to chassis.
  - c. Any securing bolts on the contact area of the bumper must have rounded heads. Please try and avoid fixing in this area, if possible.
- NB:** ALL CARS: Bumpers may have holes or slots in them, between the head lamp apertures, for cooling purposes only.

### **Grill**

The original grill must be used, in its original position.

### **Head Lamp Apertures**

- a. Must be blanked off with metal (0.5mm maximum thickness), or fibre-glass and must be hollow at the rear for scrutineering purposes.

### **Bonnet**

- a. A bulge or carburettor /air filter scoop is permitted but any opening of the scoop must be forward of the engine block.
- b. No other holes or vents in bonnet except bonnets that rap down the front of car for cooling purposes. A scrutineer's discretion is final.
- c. Bonnet may be constructed of fibre-glass.
- d. No mechanical components should be visible from the rear of bonnet, and the rear of bonnet may be extended to incorporate the windscreen shuttle panel.

### **Wheel Arches/Spats**

Front and Rear:

- a. Steel wheel arches, or spats, may be fitted and must be symmetrical. If permission granted; any new vehicle with plastic front wings may make fibre-glass replicas, incorporating the wheel arches which must be symmetrical.
- b. Wheel arches must not exceed one-third of wing area.
- c. The top of the tyres must be covered by body or spat, when viewed vertically, to prevent cars riding over each other when racing.
- d. The area from the rear bumper to wheel arch, or spat, may be filled-in, and must have smooth and rounded edges.

### **Side Skirts**

- a. Side skirts, fitted between front and rear wheel arches, are compulsory if spats or arches are fitted; they must be a maximum of 1mm thickness mild steel, and may have gussets at either end. The original outer sill may be removed, but do not remove the inner sill which retains the 25mm (1") of original floor.
- b. For the purpose of scrutineering, there must be a visible hole of 25mm in diameter on the top side of each skirt.
- c. Side skirts may have holes in them.

### **General**

Unless fitted as standard to your vehicle, the following parts, materials, methods, or practices, must not be used:

- a. Alloy or magnesium brake calipers.
- b. Alloy or magnesium hubs.
- c. Alloy or magnesium differential casing (including slipper casing).
- d. Alloy or magnesium gear box centre casings.
- e. Alloy or magnesium suspension top mounts.
- f. Stainless steel panels.
- g. Kevlar parts. Exceptions: seat, bumpers, and driver's door.
- h. Any type of moly-chrome steel.
- i. T45 steel.
- j. Tyre softener.
- k. Tyre buffing.
- l. Tyre cutting.
- m. Turbo charging and fuel injection are not permitted.

## **4. ENGINE**

The engine must be any Ford 2.0 Litre Pinto SOHC engine, meeting the following specifications:

- a. The 2.0 Litre Pinto engine may be used, with a nominal bore of 90.84mm and a stroke of 77mm, with a maximum re-bore of 1.5mm oversize.
- b. Sleeving back to 90.84mm is permitted, and over-boring of sleeves 1.5mm is permitted.
- c. Cylinder blocks may be in-line bored.
- d. Top of cylinder block may be surfaced, but pistons must not protrude above top of block and all four must have their original marking on the crown.
- e. It is permitted to secure engine core plugs with a secondary fixing.
- f. No other modification permitted.

### **Crankshaft**

- a. A standard crankshaft must be used.
- b. Tufriding and nitriding is permitted, but polishing is not permitted.
- c. Crankshaft minimum weight is 12.7kg. No forged steel cranks.
- d. It is not permitted to alter the number of bearings, or fit bearings of less than minimum width. Oversize bearings of standard or heavy duty material are permitted.
- e. Cross-drilled crankshafts are not permitted but the oil way at each journal may be relieved.

### **Engine Balancing**

- a. CRANKSHAFT—spot machining only.
  - b. CON RODS—spot machining only on the counter weight balance pad area at the big and small end. One con rod must remain original and untouched. No forged steel rods. Con rod bolts may be changed but con rods must not be drilled or modified to accept them;
  - c. PISTONS—Spot machining only and one piston must be original and untouched. All four pistons must have original marking on crown. Flywheel and clutch assembly may be balanced.
- NOTE:** Spot machining means either hand grind, drill or machine.

### **Pistons**

- a. Standard pistons or standard replacement pistons, i.e. (KS Karl Schmidt, Hepolite, Wellworthy AE, Mahle).
- b. Pistons or gudgeon pins must not be modified, and no forged pistons are allowed.
- c. Pistons must not protrude above block.
- d. The pistons must not be skimmed, and markings must remain on the pistons for identification purposes.
- e. Lightening and stress relieving is not allowed.

f. Any make of piston ring may be used, providing there is no machining of the pistons or rings other than Gapping.

### **Lubrication System**

- a. Dry and semi-dry systems are not permitted.
- b. The oil filter must have a secondary fixing, and occupy it's original position.
- c. An oil cooler may be fitted in the engine compartment, using a sandwich plate between the oil filter and block.
- d. Oil galleries in the block and head must remain unmodified.
- e. Sumps may be modified to hold more or less oil, and may be baffled to prevent surge.
- f. Group 1 and aluminium sumps are permitted.
- g. The oil pick up must terminate within the confines of the sump.
- h. High pressure oil pumps are allowed, but not high capacity.
- i. The only modification allowed to the rocker cover is for breathing purposes only.

### **Gaskets**

- a. Only standard Ford or Payen 2.0 litre gaskets may be used, including the standard American version, unmodified, with no other sealing aids.
- b. Competition gaskets are not permitted on any part of the engine or ancillaries.

### **Camshaft**

- a. Camshaft type is free.
- b. The use of Vernier cam timing wheel is permitted.
- c. Standard length 2-litre cam belts must be used, along with the standard 2-litre cam belt tensioner, unmodified.
- d. Centre drilled camshafts are allowed, the oil spray bar may be removed, and a splash shield may be fitted.
- e. Roller cam bearings are not permitted.
- f. Rocker arms are free, but the use of Roller Rocker is not permitted.
- g. Rockers may have the ends nipped.
- h. Heavy duty rocker arm retaining springs are permitted.

### **Cylinder Head**

- a. Any 2-litre casting allowed.
- b. Cylinder head must not be modified, and material must not be added or removed from the ports or combustion chamber.
- c. Valve guides, if fitted, must occupy their original position, and must be standard Ford replacement type, not bronze or competition type. The use of the thin wall bronze inserts in existing guides is permitted.
- d. Valves must be standard, and of standard Ford length (110.65mm-111.65mm inlet, and 110.10mm-112.05mm exhaust). The valve head size must be 42mm inlet and 36mm exhaust.
- e. Three-angle valve seats are permitted. The measurements of the three angle valve seats are as follows; Angle 1; Combustion chamber 30° Angle 2; Valve seat 45° Angle 3; Port 60—65° with valve seat width free.
- f. The head gasket face may be skimmed.
- g. Any single or double valve springs may be used, and the head may be modified to allow them to fit.
- h. You must use standard Ford Pinto spring tops only, and extended length ball studs are permitted.
- i. Heavy duty rocker arm retaining springs are permitted. NB: On standard inlet valves only, where the back of the valve meets the valve seat, there may be a slight lip, which may be ground away at a 30° angle, to a maximum width of 2.5mm.
- j. The centre camshaft cap maybe re-enforced.

### **Modifications**

- a. Any production type starter motor may be used (no competition types).
- b. Water pump and crankshaft pulley may be fitted with power grip-type drive belts and pulleys.
- c. Manual fuel pumps may be replaced with electric type.
- d. An adapter may be fitted to run a tachometer.

### **Flywheels & Clutch**

- a. Any standard Pinto Engine flywheel, which may be lightened, may be used.
- b. Clutches are free, but no competition types.
- c. Flywheels must be doweled to the crankshaft.

### **Distributors**

- a. The 2.0 Litre Pinto distributor (Motorcraft or Bosch), complete with points and condenser, or standard Ford 2.0 Litre Pinto electronic ignition system which uses a conventional coil.
- b. The mechanical or vacuum advance may be altered; the vacuum advance may also be removed.
- c. Only the following lumenition electronic ignition systems are permitted for use:
  - i) Ford Bosch fitting kit FK 221 with power module PMA50.
  - ii) Motorcraft fitting kit FK9 with fitting kit PMA50.

## Engine Sealing (see SECTION 30)

### Carburettor

- a. Only the standard Weber 32/36 DGV/A carburettor may be used with a maximum sized chokes of 26mm and 27mm.
- b. No polishing or re-profiling is allowed.
- c. No modification to the carburettor body or original design. The interchanging of the carburetor top from other Weber models is not allowed.
- d. Gaskets must be original or replicas of original (i.e. no modified gaskets).
- e. A single original specification adapter/insulator block must be fitted between carburettor and inlet manifold, with two gaskets approximate total thickness 5mm I.E. as supplied with Gasket set.
- f. Main jets, primary and secondary jets, auxiliary venturi, and emulsion tubes may be replaced with a different size of the same part.
- g. Accelerator pump jets may be changed, but face downwards towards butterflies.
- h. Butterflies may be modified to open together, replacement spindles may be fitted with standard screws. Cold starting devices may be removed, with retaining lugs and subsequent holes blanked off.
- i. Air and fuel galleries may not be enlarged or modified; fuel may enter needle valve/float chamber from either side. Floats may not be modified or weighted, and must control the fuel flow.
- j. Needle valves may not be larger than 250, and not enlarged or modified.
- k. The power valve must be fitted in the base of the fuel bowl, but may be sealed off, and the diaphragm may be removed.
- l. No trumpets are allowed. The calibrated brass bush which controls the high speed enrichment, fitted on the secondary venturi side of the carburetor between the top and base of the carburettor, may be sealed off or enlarged, but must be fitted.
- m. A secondary fixing on the fuel feed-line is required. It is permitted to use a grub screw, or similar device, to fix the auxiliary venturi to the carburettor body.

### Inlet Manifold

- a. Standard Pinto, and may not be faced to alter the angle of the manifold or the carburettor.
- b. No inlet port-matching from the carburettor flange face will be permitted, or from the manifold ports to the head.
- c. No material may be added to or removed from the gas flow area.
- d. Water circulation holes may be blanked-off.
- e. A stabiliser bar may be fitted to support the manifold.

### SPECIAL NOTE

All other parts appertaining to the engine, which are not mentioned above, must remain as standard manufacturer's items.

## 5. SAFETY EQUIPMENT

### 5.1 CRASH HELMET

Helmets must be of a minimum standard as directed by British Oval Racing Safety Executive (B.O.R.S.E). These are FIA8860-2004, Snell SA2005, Snell SA2010, SFI Foundation 31.1A, SFI Foundation 31.2A. The E2205 European standard helmet may be used in Fibreglass, Carbon or Tri-Composite form only i.e. NO POLYCARBONATE helmets are allowed. It is important that the helmet fits the driver correctly. Shatterproof goggles/visors must be worn although tinted visors are not advisable. Your helmet must display the current ORCi (ORC10) sticker.

### 5.2 RACING OVERALLS

You must wear Fire retardant, clean, un-torn and brightly coloured Racing Overalls that are made of a fire retardant material and are clearly marked fireproof. Mechanics are also required to wear clean overalls and will not be permitted on to the track without them being on, when instructed to do so.

### 5.3 GLOVES

It is Mandatory to wear Fire retardant Gloves also clearly marked fireproof.

### 5.4 BALACLAVAS

It is Mandatory to wear Fire retardant BalACLAVAS clearly marked fireproof.

### 5.5 NECK BRACE

A Neck Brace is recommended, a spine support is also recommended.

### 5.6 WET WEATHER CLOTHING

Wet Weather clothing is also recommended and must be worn in addition to, and **not** instead of the racing overalls.

### 5.7 HEAD RESTRAINT NET/WINDOW NETS

You may fit a Head Restraint Net on the on the safety fence side of the race car only. A quick release window net must be fitted to the driver's door window aperture and must be of quick release/cloth type only. Net spacing must be 76mm x 76mm maximum.

### 5.8 1kg FIRE EXTINGUISHER

- A 1Kg Dry Powder Gauge Fire Extinguisher is highly recommended and if fitted, this should be in a tube with a spring top and should be within easy reach of the driver. Old type BCF (green) type extinguishers are not allowed. All tow vehicles, must carry a minimum of a 2kg fire extinguisher dry powder or gas, which must be within easy reach of the driver and mechanics at all times, especially when refueling.

### 5.9 COMPETITION STYLE DRIVERS SEAT WITH HEAD RESTRAINT

You must have a Competition type Driving Seat with a head restraint. The seat should occupy its original position where possible and be suitably supported at shoulder height and on both of the sides and back, with a suitable framework or seat stiffener's.

Additional wrap around seat support at shoulder height.

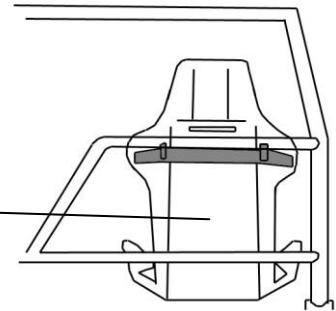

### 5.10 SAFETY HARNESS

The lap belt/straps and crotch straps should not pass over the sides of the seat, but through it, in order to wrap and hold the pelvic region over the greatest possible surface

It is mandatory to have a 5 point Safety harness with 3" shoulder straps, the lap & crutch straps can be either 2" or 3" in width.

All seatbelt connection points must be visible and no belts must pass through any firewall.

Following research made by leading safety harness manufacturers, information has been made available with regard to the best way to fit your safety harness; this will further ensure your safety. Please study the diagrams to ensure your safety harness is fitted correctly.

The lap belt crossing should be below the anterior-superior iliac spines (bony part of the hip). Under no circumstances should it be worn over the region of the abdomen.

Lap belt/straps **must terminate vertically downwards**, and not forwards or rearwards of the hip joint. Lap straps should terminate symmetrically about the wearer on either side of the seat, about 20" (500mm) apart. The distance between the seating surface and the anchorage point should be kept to a minimum to prevent submarining.

The location of the crotch strap mounting should be to the rear of the driver.

Fig.1 shows the location for the tail straps, which should be horizontal to 20° below horizontal, and as close to the shoulder as is practical for optimum restraint.

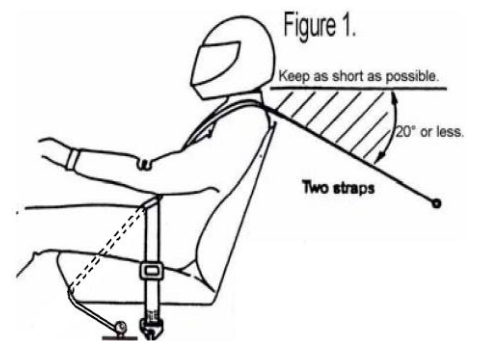

Only safety belts comprising of separate shoulder, lap, and sub-straps will be permitted.

The sub-strap must be used at all times, and all belts must connect to the quick release buckle. The abdominal strap fixing point must be on the chassis, roll cage, or floor (for vehicles with no chassis), either side of the driver.

The shoulder straps must be supported at shoulder height. NASCAR type buckles must be fitted with lever on the **right** side of the driver. It is advisable to fit a secondary means of detent to prevent overall sleeves accidentally unhooking the buckle during racing. A small section of tube grip **elasticated** bandage, slid over the hooked buckle, serves the purpose.

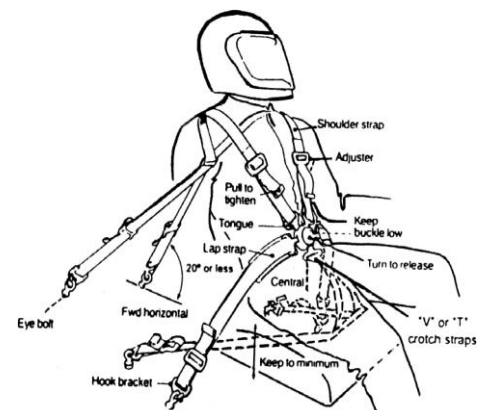

Special attention must be paid to the condition of seat belt fixings once fitted. Information is available, from your Promotion, on the correct procedure to follow when fitting seat belts. *Remember - your life depends on them, and belts, once involved in a severe accident, should be discarded and replaced.*



Over the years, we have had many unnecessary injuries due to badly fitted seats. They frequently occur in Non-contact Formulas, when perhaps a driver believes it is more unlikely that he will be involved in a serious crash, and he also believes that, if he is involved in a collision, the impact on his car will be from the front. However, this is often not the case. It is therefore, imperative that you ensure your seat is really well supported, especially where the shoulder straps go through. You must also ensure that your seat cannot move sideways.

The safety of your seat will be judged by the Scrutineers and you will only be permitted to race when they are satisfied that you will be as safe as possible in any event.

## 6. PERSONAL SAFETY

Drivers are advised that under Health & Safety, they are responsible for their own and their Mechanic's actions. Promoters have had complaints made about Registered Drivers & Mechanics consuming large amounts of alcohol at meetings, which could effect their judgement or be detrimental to their health, when medical attention has to be administered by Paramedics, St Johns or Hospital Staff.

Should an incident occur that proves fatal on the raceway and you are involved, it is likely that the Police will want interview you. **If you drive, don't drink!** Scrutineers and Officials will report to the Clerk of the Course, anybody they believe is under the influence of Drink or Drugs. Drivers whom it is thought are under the influence may be breathalysed.

**Drivers should line up on the grid with their engines switched off in the correct points order, unless told otherwise.**

### The Flags

This is to remind drivers of the flag signals as used by the Starting Marshall and Safety Marshalls on track.

- Waved Green Flag – Go, the race has started.
- Waved Red Flag – Stop racing slow down & stop.
- Chequered Flag – Race winner has crossed the line, continue to race until the Red Flag is shown.
- Held Yellow Flag – Beware, you are approaching a hazard on the track, continue to race.
- Waved Yellow – Slow down to 15mph, hold your position, and do not overtake any other cars.
- Waved Blue Flag – Shown to a driver who must hold his racing line. Driver must either hold a line on the inner part of the track or the outer part of the track, not weave between both.
- Blue & White Flag – Give up your track position, you have not taken notice of the Blue flags.
- White Flag with a Blue spot – Oil on the track.
- Waved Black Flag - You are disqualified, pull off the track immediately.
- Black cross on a White board – You have committed an infringement and may be penalised in the results.
- White Flag with a Red Cross – Technical Disqualification, leave the track immediately

## 7. ROLL CAGE

a. Alloy roll cages are not permitted.

b. A full roll cage; minimum material size and gauge of all tube as listed below is 32mm (3mm) or 38mm (2.5mm)OD; (which must support both A & B pillars), consisting of a minimum of:

- Two hoops, either running from front-to-rear or side-to-side.
- Two top hoop connecting bars.
- One rear hoop cross bar at shoulder height to mount seat support, or a seat brace hoop to mount seat support.
- One lower bar (recommended).
- One dash cross bar.
- Two driver's-side chicken bars (plus connecting bracing).

Two passenger-side chicken bars (plus connecting bracing). The roll cage hoop feet must be welded to four 3mm thick plates, 230mm square, welded to the floor, or a piece of tube or box (38mm x 38mm x 2.5mm minimum thickness) connecting front and rear hoop feet welded to sill or floor, and two separate chicken bars are still required, unless the roll cage is an integral part of the space frame. See Section 3 Bodywork/Spaceframe.

c. All structural bars connecting to the cage inside the car must be steel, and terminate a minimum of 100mm (4") from the front and rear panel. Any part of the roll cage that may come into direct contact with the driver's body must be suitably padded. All joints must be welded over a minimum of 90% of the surface area of the joint. RAC Approved cages are permitted, with a minimum thickness of 2.5mm. It is important there are no large gaps between any part of the cage, and the body shell. Roll hoops and connecting bars must not be dropped from roof, and must support the A & B pillars. It is permitted to move the 'B' pillar hoop rearwards to protect Drivers Head. Please bear in mind the seat should occupy its' original position.

## 8. ENGINE POSITION

### Front-to-Rear

a. Will be determined by the following calculation, measured from the axle centre-line to the rear of the engine block or bell housing face:  $50\% \text{ of original wheelbase} + 711\text{mm (28")}$ .

b. This is the minimum measurement, and any wheelbase tolerance cannot be included in this calculation.

### Side-to-Side

2.0 Litre Ford OHC. See diagram on next page:

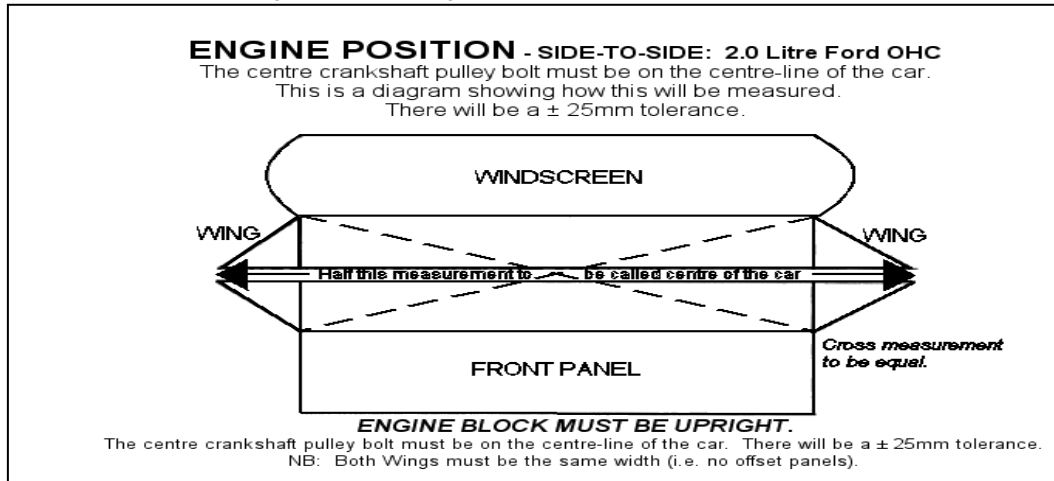

## 9. GEARBOX & FINAL DRIVE

- a. The only gear boxes permitted for use are the single rail, 2.0 Litre Cortina type 4-speed gear boxes, including 4-speed P100, 1600 Sierra and 1600 Cortina. It must be fitted as manufactured. Gears must not be changed or altered, i.e. no removal of gears or components, and no straight cut or close ratio gear sets (other than the Trans-X stock car box or the Quaife gear sets (Hot Rod Box), with a maximum cost of the gear set not exceeding **£600.00 plus VAT**).
- b. Differentials may be free, locked or the limited slip diff. only may be used.
- c. It is permitted to use the 5-speed 2.8 Capri/Granada or 1600cc/2.0Ltr 5 speed Sierra gear box normally for long track use, either with an adaptor/spacer plate, or you may reduce the length of the first motion shaft to allow correct fitting. Gears must not be changed or altered I.E. no removal of gears or components and no straight cut or close ratio gear sets.
- d. The only exception is that the gear change assembly may be altered; this may include part of the tail-shaft housing associated with the gear change only. Aluminium bell housings are permitted, unmodified. A clutch is required, and must be operated by a pivot arm from the  $\pm$  outside of the bell housing.

## 10. OIL COOLERS

Oil coolers are free but must stay within the confines of the engine compartment.

## 11. VEHICLE WEIGHT & BALLAST

**IMPORTANT NOTE TO ALL FORMULAS:** Cars may be checked at the end of a race. They must, at this time, meet the minimum and/or maximum permitted weights for each Formula, as listed below. Drivers should allow for wear of brakes, tyres, and use of fluids during a race which, depending on the length of a race, can be in excess of 3+kg. Infringement of this Rule, in most Formulas, carries a statutory race ban.

**All weights exclude driver.**

Underweight Vehicle Bans	
Car Underweight by:	Banned From Racing For:
0.001kg – 1.0kg	1 month
1.001kg – 2.0kg	2 months
2.001kg – 3.0kg	3 months
3.001kg & over	6 months

The minimum weight for the Hot Rod will be 700kg at any time. Any ballast must be welded in place (not bolted). Ballast, if required is not restricted to being within the reach of the driver.

The maximum right side weight will be 53.5%.

- a. If you are checked and over the 53.5% but under 54% you will lose all points/monies due on the day and receive a final warning.
- b. If you are found on a second occasion to be over 53.5% but under 54% you will receive a one meeting suspension, lose all points/monies due on the day. Anyone over 54% on their first check will receive an automatic one meeting ban, and loaded immediately with loss of any points or monies due (if applicable).
- c. If a driver is found over 54% on a second occasion the penalty will automatically be doubled, or possibly carry a longer suspension. Checks will be carried out at any time.

## 12. BRAKES

To be effective on all four wheels, bias braking permitted, disc brakes on the rear of the car are also permitted, parking brakes optional. A secondary system must be fitted if not using the bias braking method. Alloy calipers,

or four pot brake callipers, are not permitted. Only steel disc or drums permitted. (Drilling of disc/drums is permitted).

### 13. AEROFOIL/REAR WING & ROOF SPOILER

**These are permitted within the following confines:**

The aerofoil referred to in this paragraph means one wing and two side fins.

- a. One aerofoil may be fitted, and must be above driver's sight line.
- b. The main wing must not be positioned further forward than the rear axle centre line.
- c. The aerofoil must be constructed in aluminium or fibre-glass.
- d. The aerofoil with side fins must be within the vertical confines of the original body shell, including moulded in bumpers when viewed at rear and side.
- e. The aerofoil wing only must not exceed 305mm (12") in height above roof line.
- f. The aerofoil wing must not exceed 457mm (18") length, front-to-rear.
- g. Side fins must be of equal size and equal position, and should not exceed 356mm (14") above roof line, should not exceed length of wing, front-to-rear, by more than 51mm (2") at either end, and must not exceed 406mm (16") in height.
- h. Numbers on side fins must be a minimum of 229mm (9") high by 38mm (1.5") strokes, black on white.
- i. A roof spoiler is permitted, must not exceed 152mm (6") above roof line, and must stay within the vertical and horizontal confines of the vehicle.

**NB:** If an aerofoil with side fins is not used (see **24. Racing Numbers**).

### 14. WHEELS & TYRES

Wheel rim width of a minimum of 6" and a maximum of 8" only will be used. The Hot Rod Formula has a one tyre regulation, which is the Hoosier Sportsman A70.13 22.5 x 7.0 x 13.0 hard or soft compound. The current price can be found by contacting Hoosier Tires on 01293 863579.

**Tyre Management:** Tyre buffing is not permitted but the removal of debris and old rubber from the tyre with a hand held rasp or tyre glove is permitted.

**Tyre Ruling:** One new tyre per meeting may be used, along with any 4 old tyres that have been previously used and declared (except at Eastbourne & Northampton where you may use more old tyres). These used tyres **MUST** appear in the drivers tyre history. Just because a tyre has been previously declared does not make it a used tyre, this will be the Scrutineers decision. The only exceptions to this is Major Championships where the number of new tyres allowed will be confirmed prior to the Championship meeting.

New drivers may use 4 new tyres for their first meeting but must start at the rear of the grid for their first 3 meetings.

**Wet Meetings: If the Steward of the Meeting declares a wet race/meeting, upto 4 new tyres may be used, but these MUST have been declared on the tyre declaration sheet prior to the start of the meeting.**

### 15. EXHAUST SYSTEMS

**Note for all Formulas:** If a silencer becomes ineffective or insecure during racing, the driver should automatically pull off. If the exhaust becomes ineffective within the last five laps, it may not be possible for the Start Marshal to issue a Black Flag, but you will automatically be removed from any result. Silencers must be effective in reducing noise.

- a. Exhaust manifolds are free.
- b. Any exhaust system passing through the driver's cockpit must be fully covered by a metal shield.
- c. Tail pipes. There must be a minimum of 76mm (2") and a maximum of 254mm (10") of tail pipe on the silencer, and must terminate rearwards or downwards under the vehicle.
- d. Cars should be fitted with either of the following silencers in standard form:
  - i. AX891
  - ii. Fordson Major Box E1ADDN5320A or available in cross reference.
  - iii. Simpson MS500.

### 16. COOLING SYSTEMS

Radiators are free, and must be forward of the engine in the engine compartment.

### 17. LIFTING EYES

Must be fitted with two lifting eyes under the bonnet, near turret tops or shock absorbers, and must not protrude from the front of the car. Also, two lifting eyes must be fitted at the rear, in the boot area, and must not protrude from the rear bumper or the rear panel. If your vehicle has a chassis or roll cage member which can be utilised in these areas, the lifting eyes do not have to be fitted.

### 18. WINDSCREENS/GLASS

- a. All glass must be removed.

- b. Laminated, perspex, or lexan front screens are permitted, but not recommended. They must have fitted and working washers and wipers, and a secondary form of fixing, and must not be bonded. You may not fit glass, perspex, or lexan into the driver's side, or passenger's side, front or rear door window apertures, or anything which may restrict access to vehicle. .
- c. A metal upright, to a maximum 38mm, minimum 19mm, box or tube section, **must** be welded or bolted to the centre of the front windscreen aperture, or multiple equi-distantly in the front windscreen aperture.
- d. A wire mesh panel covering the driver's side of the screen is not permitted.

## 19. STOP LIGHTS

Either two stop/brake lights, or a centrally-fitted single stop/brake strip-light, must be fitted onto the parcel shelf, or hung from the roof in the case of hatchbacks. If two lights, they must be a minimum of 762mm (30") apart, facing rearward. Lamps must be operated by the standard switch, as fitted to the car. No other switches or modifications are allowed. Lamps must be a minimum of 76mm (3"), and a maximum of 127mm (5"), diameter square/rectangle. Bulbs must be of 21 watt intensity. Strip type lamps should be no wider than 406mm (16").

## 20. MIRRORS/GLASS

- a. Driver's side external door mirror must be fitted, and must not protrude beyond the extreme body width of the car. It should be of a spring-loaded or sheer type.
- b. A passenger side exterior mirror is recommended - it should be of a spring-loaded or sheer type.
- c. A rear-view interior mirror must be fitted.
- d. The size of the mirror approximately 152 x 100mm (6" x 4") maximum, and, if glass, should be covered with a clear plastic to prevent the glass from fragmenting.

## 21. OIL CATCH TANK

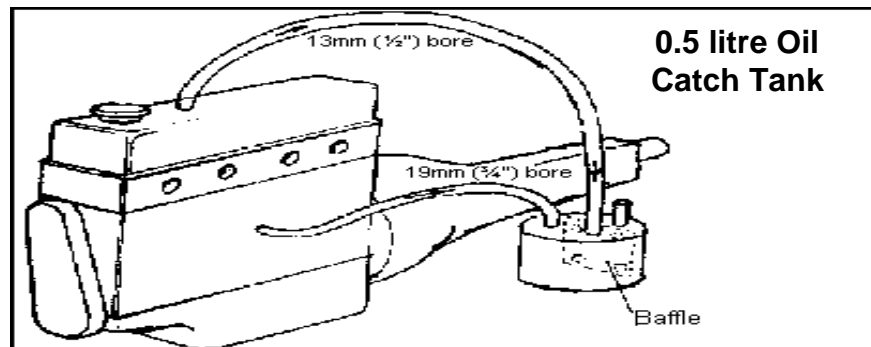

An oil catch tank, with a minimum capacity of 0.5 litres, must be fitted in the engine bay, and must have a minimum of two breather pipes connecting to it, one from the rocker box and one from the crank case. If the catch tank becomes ineffective during racing or practice, the car will be withdrawn from the event.

## 22. BATTERIES & ELECTRICAL SYSTEM

- a. Battery(ies) must be securely fixed and covered with a rot-proof material if they are not of a sealed type.
- b. A battery tray/s with adequate clamps (no battery boxes)
- c. Contact between the safety harness and battery must not be possible.
- d. Battery must be a minimum of 152mm (6") from the fuel tank.
- e. The battery position is free and a maximum of two batteries are allowed. Oversized batteries being used as ballast are not permitted.
- f. A battery master switch must also be fitted in the area of the rear left-hand window, and must be clearly marked "ON/OFF", or have an Electricity Danger Decal.
- g. If an electric fuel pump is permitted for your Formula, a switch must be fitted within easy reach of the driver.
- h. A self-starter motor must be fitted, and in working order at all times.

## 23. FUEL TANKS & SYSTEM

- a. All fuel tanks must have a positive means of fixing (metal straps or bolted).
- b. Filler caps must not be prone to spillage - no push-on caps. Caps must be metal and secure, or screw-on type.
- c. Fuel tanks, including filler caps, must be covered by a metal firewall.
- d. Fuel outlet must be from top of tank.
- e. A breather pipe, which must incorporate a one-way valve, must be fitted (or a vent pipe, terminating below the tank, so it would prevent spillage if inverted).
- f. All fuel pipes must be inside vehicle.

- g. Only road-side fuel can be used (either BP Ultimate (NOT 102) or Shell V-Power or Esso Supreme). No additives permitted I.E. Upper cylinder lubricants, Octane booster. For full fuel specification please see last page of these rules.
- h. If there is a floor under the tank, there must be four 50mm holes in the floor, in case of spillage.
- i. A fuel shut-off tap must be fitted within easy reach of driver.
- j. Fuel lines must be metal, or metal covered
- k. A single electric pump may be used in place of original.
- l. Fuel tanks must be metal only, or FIA approved.
- m. Fuel regulators are permitted.

**Check below for the size and position of Fuel Tank:**

- a. Carburettor banjo bolts must be drilled and lock-wired.
- b. A single electric pump with regulator may be used.
- c. Fuel tank with maximum capacity of 18 litres (metal only).
- d. Fuel tank must be fitted in front of the rear axle and behind the driver.
- e. Fuel tank must be covered by a complete metal firewall, or a metal firewall separating driver from tank.
- f. There must be a minimum gap of 152mm (6") between fuel tank and batteries.

## 24. RACING NUMBERS & DRIVERS' NAME

- a. **SIDE OF CAR.** The driver's racing number must appear on both sides of the car. Preferably, these should be in large, American-style numbers on a contrasting background. Background must extend a minimum of 50mm (2") beyond the outline of the number(s).
- b. **FIN PLATE(S).** Must be used if aerofoil is not applicable, and the numbers must be a minimum of 229mm (9") high by 38mm (1.5") stroke, black on white background, fitted above the roof-line, but must not be higher than 305mm (12") in total, and 559mm (22") in length.
- c. **AEROFOIL/FIN PLATES.** Numbers should be a minimum of 229mm (9") high by 38mm (1.5") stroke (black on white background), on each side fin so visible from both sides of the car.
- d. **DRIVERS' NAME.** A sun visor, to an approximate depth of 152mm (6"), with your name or nickname clearly signwritten, must be fitted. All sign-writing must be approved by the Promotion; other names permitted are those of sponsors and mechanics only.

## 25. ROOF GRADING

All cars must have 90% of their roof painted (or a minimum of a 609mm (24") wide stripe), with a 51mm (2") wide stripe either side - in contrasting colours - from the front to the rear, in their roof grade colours. The grading strip must not have any sign-writing on it. If you win a race at a meeting; you will start the remaining races from the rear of your grade. Should you win another race at the same meeting – you will be automatically upgraded.

**Multi-Champions will start next to the World Champion.**

**Grid Line up / Roof Order:**

White (Novice)  
 Yellow  
 Blue  
 Red  
 Superstar (Red, White & Blue Stripes)  
 Silver Roof – Current National Leader  
 White with Red Cross – English Champion  
 Blue with a White Cross – Scottish Champion  
 Gold Stripe – National Champion  
 Black & White Chequered – British Champion  
 Red & Yellow Chequered – European Champion  
 Gold – World Champion.

All roof grade champions must start from the rear of the grid. The only exception to this Rule is where time trials, or specific grid orders, are implemented. Any of the champions, racing together, should start in order, as listed on next page: i.e. World Champion at the back of the grid, etc.

## 26. FINAL PREPARATIONS & COLOURS

Make sure that, in the construction of your car, you have not included any flammable material; all original interior and exterior trim, mouldings, and wiring, must be removed (unless stated otherwise). The external painting of the car must, at all times, be of professional appearance — preferably in bright colours, although any colour scheme is permitted. A maximum of two cars may be painted in team colours, or painted to look similar to another car, unless it is required and specifically stated by the Promotion (i.e. Team Events). All sign-writing must be of a professional nature. Scrutineers are instructed to refuse any car which they consider unsafe, unsightly, or in any way offensive.

## 27. SCRUTINEERING OF NEW CARS

A new car or space frame to be introduced into the formula, must have permission from

Spedeworth before it is built, and once ready to race, must be scrutineered at a meeting prior to the first meeting where it is intended to be raced.

## 28. TRANSPONDERS

A timing transponder must be mounted above the floor with a 3" hole so that the transponder has a direct line of sight to the track, it must be fitted between the two 'B'. The beam is projected at an angle, so the further you fit the transponder away from the floor the larger the hole will need to be. The distance will be checked randomly and you will risk exclusion if your transponder is fitted further forward than the required distance. Transponders must be securely fitted and must have a permanent feed only being disabled by the master isolator. It would take a number of weeks to flatten a battery with the small current these units draw. You will be informed after practice if your module is not functioning, but following that if your transponder is still not working then you will not be lap scored electronically.

## 29. VIOLATIONS

- a. When referring to the engine, gearbox, differential, mechanical, or construction Rules & Regulations, the principle will always be:
- b. Unless permission is specifically granted to make modifications (or any variation), nothing may be done to alter or change the Standard Parts in any way.
- c. Presentation of a vehicle for Scrutineering is a declaration by the entrant that the vehicle is eligible for that event.
- d. Car, engines, and fuel will be checked on a random basis. Violations, or refusal to allow an engine check, will result in an immediate suspension of all racing facilities.
- e. All car and engine specifications will be taken from either the manufacturer's Technical Specification Books, or the Technical Service Data Books for cars, as published by Glass's Guide Service Limited. If there are any discrepancies occurring between books, the Promotion will exercise its' judgement, which will be final in any dispute.
- f. Clarification on any item may be sought from Spedeworth.
- g. Each driver is permitted only one car per meeting, and each car is permitted only one driver per meeting.

## 30. ENGINE SEALING

- a. Spedeworth: We may at any time require your engine, or other parts sealed. This may or may not mean your engine/parts will automatically be stripped or checked. It could be we wish to monitor your performance or seek clarification on any item. It is normal to strip engines/parts at all major championships unless they run consecutively in which case with agreement of Spedeworth stripping may be postponed (see below).
- b. Driver: Drivers wishing to have their engine sealed may do so. It will require two people (one may be an official, the other a Scrutineer) to be present at the final stages of build and will incur a charge based on the time and distance travelled. If this option is taken at major championships your engine will not require stripping, unless seals are not intact. Seals can only be removed by Spedeworth officials and if removed without permission the engine/parts will be deemed illegal and the driver suspended pending Board of Control.. If any engine/parts are sealed because Championship events are within a period, which may exclude that driver due to the rebuild time. A driver may, with Spedeworths' agreement, postpone stripping for three meetings maximum.
- c. Provision for sealing must be made on either side of the sump, two head bolts (if not covered, in part or wholly, by rocker cover), two inlet manifold bolts, and two rocker cover bolts. If this is not done, you will lose the opportunity to have your engine sealed.

## 31. RULE CHANGES

The Promotion may, at any time, make amendments to the specifications, in the interests of safety. It may also make amendments in the interest of expense to the driver or in areas that are determined to be detrimental to the future of the formula. Also if unnecessary advantage has been deemed. Additionally if it is felt the Formula is drifting away from its original concept. Current registered drivers will be notified automatically, but if you are building a new car from these specifications, please check with Spedeworth, who will advise of any amendments. It is the responsibility of the driver to prove to the Promotion that the part is legal, by way of written proof of where the part originated. This must be undertaken within seven days, otherwise the part(s) in question will be deemed to be illegal, resulting in immediate suspension from racing and referral for disciplinary action. Unless these Rules state you can do it, you **CANNOT DO IT**.

# PRIMARY & SECONDARY FUEL ENRICHMENT SUPERSTOX, 2.0 Litre HOT RODS, & LIGHTNING RODS

(see Lightning Rods Exception in D. below)

Diagram 1. shows fuel enrichment under heavy acceleration, and Diagram 2. shows high speed fuel enrichment, both of which have caused Drivers and Engine Builders confusion regarding which Formulas have them fully operational, and which do not.

So, for the future, the following Regulation for the Formulas will apply:

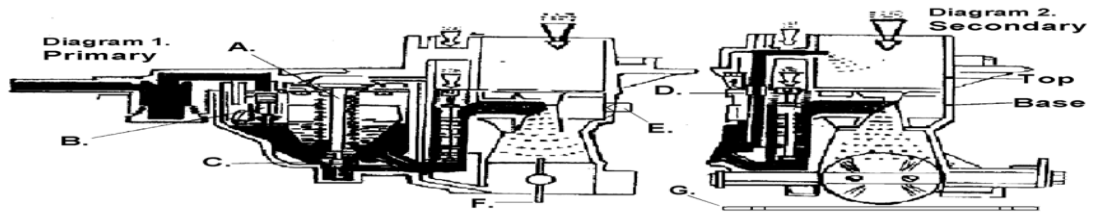

- A. Indicates diaphragm and rod which operates the power valve. This may be operational or removed.
  - B. Indicates needle valve, which controls fuel supply. This must be a maximum of 250 (indicated on side of needle valve).
  - C. Indicates power valve, which must be fitted, but may be sealed-off.
  - D. Indicates a calibrated bush, which is fitted on the secondary side of the carburettor, between the top and the base. This bush must be fitted, but may be sealed-off or enlarged.  
*(Exception: Lightning Rods – the bush may not be blanked-off or modified.)*
  - E. It is permitted to use a grub screw, or similar device, to fix the auxiliary venturi to the carburettor body.
  - F. Primary and secondary throttle valve/butterflies may be modified to open together.
  - G. A single adaptor/insulator block (approximately 5mm thick, including two gaskets), must be fitted between carburettor and inlet manifold.
- NO OTHER MODIFICATIONS TO ANY OF THE ABOVE WILL BE PERMITTED.

## SUGGESTED WEIGHT DISTRIBUTION:

The diagram here relates to Anti-clockwise Formulas only. Please reverse weight distribution for clockwise formulas. For tarmac track cars, use the following weight distribution as a good guide:

**Left side—58%, Rear—50% - 51.5%, Cross Weight—54% - 57.5%**

For left side weight percentage on a tarmac track, use as much as possible so that the left and right sides of the car are closer to being balanced during cornering. For rear weight percentage, 50% to 50.5% is used on faster tracks, while 51% to 51.5% is used on ¼ mile tracks. Cross weight is used to keep the chassis tight during cornering. It is advisable to run as little as possible. Use just enough to balance the car. More cross weight heats up the right front and left rear tyres more, making it a three wheel race car. You want a balanced combination that gets more weight on the left front. The basic range of cross weight is 54% to 57.5%.

**IMPORTANT NOTE:** National Hot Rods and 2.0Litre Hot Rods have a maximum right side percentage weight.

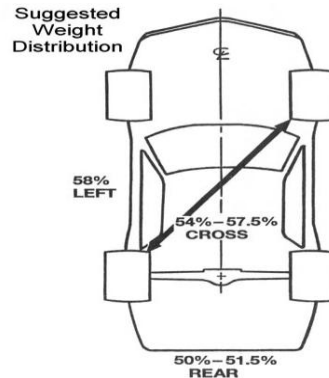

## 32. FUEL SPECIFICATION

**All Oval Racing Formulae:** Permitted fuel specification from 1<sup>st</sup> January 2008 (this specification supersedes all previous specs).

1. All cars must only use fuel from roadside pumps as defined below.  
Petrol (Motor Gasoline of the type on sale to the general public from roadside filling stations) BS 4040 (Leaded) Subject to a valid permit for use. LRG (Unleaded), BS EN 228 (Unleaded), BS7800 (Super Unleaded).
2. Petrol is a product refined from crude oil that contains a large number of identifiable compounds that can typically be 250 in number. These compounds can be identified and compared to the available petrol from major oil companies and suppliers.
3. Unless otherwise stated, or the distinction is made between leaded and unleaded petrol, major gasoline fuel shall meet the following; Acceptance levels for Octane numbers will be determined at 95% confidence level. Only additives to this motor gasoline fuel solely for the purpose of lead replacement are allowed.
4. Lead Replacement Gasoline, LRG, also known as LRP. Only additives from Sodium, Phosphorous,

Potassium, or Manganese according to manufacturers recommendations are allowed. Note; Manganese can enhance octane values in any petrol. Under no circumstances will values in excess of 0.005 grams/litre be permitted.

**Lead in excess of EU directive 98/70EC requirements is illegal.**

- We reserve the right to amend the detail of the above specification to reflect any change occurring in the quality of the fuel on sale to the general public at any time.

**Roadside fuel consistency when testing fuel samples.**

	<b>BS EN 228</b>	<b>BS 7800</b>	<b>BS 4040</b>	<b>LRG/LRP</b>	<b>Test Standard</b>
Motor Oct No (max)	89.0	89.0	89.0	89.0	ASTM D2700/86
Mon (min)	85.0	86.0	86.0	86.0	ASTM D2700/86
Research Oct No (max)	100.0	100.0	100.0	100.0	ASTM D2699/86
Ron (min)	95.0	97.0	97.0	97.0	ASTM D2699/86
Lead (max)	0.005	0.005	0.15		ASTM D3341 / IP362
Lead (min)	ASTM D3237	ASTM D3237		0.005	ASTM D3237 / D3341 / IP362
Density @ 15°	0.720 - 0.775	0.720 - 0.775	0.720 - 0.775	0.720 - 0.775	ASTM D1298/ D4052
Oxygen % max	2.7% w/w	2.7% w/w	2.7% w/w	2.7% w/w	Elemental
Nitrogen % max	0.1% w/w	0.1% w/w	0.1% w/w	0.1% w/w	ASTM D4629/ IP379
Benzene % max	1.0% v/v	1.0% v/v	1.0% v/v	1.0% v/v	EN238
Sulphur	150mg/kg	150mg/kg	150mg/kg	150mg/kg	EN ISO 14596 / ASTM D2622
Olefins*	18% v/v	18% v/v	18% v/v	18% v/v	ASTM D1319
Aromatics*	42% v/v	42% v/v	42% v/v	42% v/v	ASTM D1319

\* Olefins and Aromatics values are expressed as a percentage of total fuel.