



2010 Rules & Regulations 2 Litre STOCKCAR

1.	THE FORMULA	2
2.	ELIGIBLE CARS	2
3.	VIOLATIONS	2
4.	PERSONAL SAFETY	3
5.	SAFETY EQUIPMENT	3
	1. CRASH HELMET	3
	2. RACING OVERALLS	3
	3. GLOVES	4
	4. BALACLAVAS	4
	5. NECK BRACE	4
	6. WET WEATHER CLOTHING	4
	7. WINDOW NET	4
	8. 1kg FIRE EXTINGUISHER	4
	9. COMPETITION STYLE DRIVERS SEAT WITH HEAD RESTRAINT	4
	10. SAFETY HARNESS	4
6.	ROLL CAGE	5
7.	STRAIGHT THROUGH IRONS	6
8.	FRONT BUMPER IRONS	6
9.	REAR BUMPER IRONS	6
10.	SIDE IRONS	6
11.	NEARSIDE FRONT WHEEL IRONS	6
12.	REAR WING IRONS AND REAR WHEEL PROTECTION	7
13.	DOOR IRONS	7
14.	SUSPENSION GENERAL	7
15.	OSF SUSPENSION	7
16.	NSF SUSPENSION	7
17.	REAR SUSPENSION	7
18.	THE STEERING	8
19.	THE SPRINGS	8
20.	RIDE HEIGHT & WEIGHT	8
21.	SHOCK ABSORBERS	8
22.	WHEEL RIMS	8
23.	TYRES	8
24.	REAR AXLE & FINAL DRIVE	8
25.	GEARBOX & PROPELLER SHAFT	9
26.	ENGINE	9
27.	ENGINE SEALING	9
28.	OIL CATCH TANK	10
29.	IGNITION SYSTEM - DISTRIBUTOR	10
30.	CARBURETTOR & INLET MANIFOLD	10
31.	FUEL SYSTEM	10
32.	EXHAUST SYSTEM	11
33.	BATTERIES & THE ELECTRICAL SYSTEM	11
34.	INTERIOR MIRROR	12
35.	BODYWORK	12
36.	PAINTWORK	12
37.	SUN VISOR	12
38.	FIN PLATES & ROOF NUMBER	12
39.	DOOR NUMBERS	12
40.	SPECIFICATION AND RULE CHANGES	12
41.	ROOF GRADING	13
42.	SCRUTINEERING OF NEW CARS	13

2 Litre STOCKCAR Specifications 2010

1. THE FORMULA

The object of the race is to complete the specified number of laps in the shortest time. You may push a car from behind or spin a car to the inside of the circuit. You must not lean or spin a car into the safety fence or deliberately follow a car into the safety fence on the entry to a bend (whether from the rear or side of the car). Attacking the car from the safety infield is also not permitted.

Actions deemed to be deliberate or dangerous will carry penalties.



Racing is in a clockwise direction on a clearly defined circuit with a separate infield. Any wheels passing over the demarcation lines or entering on to the grassed infield areas will mean that the driver will be penalised.

2. ELIGIBLE CARS

The only car eligible for use is the R.H.D. Ford Sierra / Sapphire 1993cc 2 or 4 door models. No Cosworth, 4x4's, or fuel injected models are allowed.

3. VIOLATIONS

1. When referring to the engine, gearbox, final drive, mechanical or construction Rules & Regulations, the principle will always be: *Unless permission is specifically granted to make modifications, (or any variation) nothing may be done to alter or change the Standard Parts in any way.*
2. It is the responsibility of the Driver to prove to the Promotion that the part is legal, by way of written proof of where the part originated. This must be undertaken within 7 days, otherwise the item in question will be deemed illegal, resulting in immediate suspension from racing & referral for disciplinary action. **Unless the rules say you can do it, you cannot do it!**
3. Presentation of a Vehicle for Scrutineering is a declaration by the entrant that the vehicle is eligible for that event.
4. Car engines & fuel will be checked on a random basis. Violations or refusal to allow an engine check will result in an immediate suspension of all racing facilities.
5. All Car and Engine Specifications will be taken from either the manufacturers Technical Specifications or the Technical Service Data books as published by Glass's Guide.
6. Should a discrepancy occur between the Specifications then the Promotion will exercise its judgement, and that decision will be final.
7. Clarification on any one item may be sought from the Promoter.
8. Each driver is permitted one car per meeting & each car is permitted one driver per meeting.
9. **Drivers have been advised to keep check on other cars.**

10. *Anyone found to be illegal with engine or suspension parts to be awarded a minimum of 3 months racing ban. (Drivers committee to finalise bans when possible)*

4. PERSONAL SAFETY

Drivers are advised that under Health & Safety, they are responsible for their own and their Mechanic's actions. Promoters have had complaints made about Registered Drivers & Mechanics consuming large amounts of alcohol at meetings, which could effect their judgement or be detrimental to their health, when medical attention has to be administered by Paramedics, St Johns or Hospital Staff. Should an incident occur that proves fatal on the raceway and you are involved, it is likely that the Police will want interview you. **If you drive, don't drink!** Scrutineers and Officials will report to the Clerk of the Course, anybody they believe is under the influence of Drink or Drugs. Drivers whom it is thought are under the influence may be breathalysed. You have been warned!

It is also apparent that some drivers are not aware of the flags used by the track staff so here is a reminder:

- Waved Green Flag – Go, the race is on.
- Waved Red Flag – Stop racing slow down & stop.
- Chequered Flag – Race winner has crossed the line, continue to race until the Red Flag is shown.
- Held Yellow Flag – Beware, you are approaching a hazard on the track, continue to race.
- Waved Yellow – Slow down to 15mph, hold your position, do not overtake any other cars.
- Waved Blue Flag – Shown to a driver who must hold his racing line. Driver must either hold a line on the inner part of the track or the outer part of the track, not weave between both.
- Blue & White Flag – Give up your track position, you have not taken notice of the Blue flags.
- White Flag with a Blue spot – Oil on the track.
- Waved Black Flag - You are disqualified, pull off the track immediately.
- Black cross on a White board – You have committed an infringement and may be penalised in the results.

Drivers are also reminded that they should line up on the grid with their engines switched off in the correct points order, unless told otherwise.

5. SAFETY EQUIPMENT

1. CRASH HELMET

A Crash Helmet having a minimum specification as detailed by the British Oval Racing Safety Executive (BORSE). **Shatterproof** visors or goggles must be worn for racing or practice. Tinted visors are not advisable. **Your helmet must display the current ORCI (ORC09) sticker.**
It is important that the helmet fits the driver correctly.

Polycarbonate (Plastic) helmets of any type are not permitted.

Helmet minimum specification : (as detailed by BORSE)		
FIA		8860- 2004
British Standards Institute	1	BS6658 - 85 Type A
Great Britain	2	BS6658 - 85 Type A FR
The Snell Foundation	1	SA2000 - SA2005
USA:	2	SF1 Foundation 31.1A or 31.2A
The European E22 Standard	1	With Serial Number starting 05
:	2	Fibre Glass or Fibre Glass/KEVLAR Or <i>Tri</i> – Composite form only

2. RACING OVERALLS

You must wear Fire retardant, clean, un-torn and brightly coloured Racing Overalls, that are made of a fire retardant material and are clearly marked fireproof. Mechanics are also required to wear clean overalls and will not be permitted on to the track without them being on, when instructed to do so.

3. GLOVES

It is Mandatory to wear Fire retardant Gloves also clearly marked fireproof.

4. BALACLAVAS

It is Mandatory to wear Fire retardant BalACLAVAS clearly marked fireproof.

5. NECK BRACE

A Neck Brace is recommended but not compulsory, so to is a spine support.

6. WET WEATHER CLOTHING

Wet Weather clothing is also recommended and must be worn in addition to, and **not** instead of the racing overalls.

7. WINDOW NET

You must have a cloth type Window Net with a maximum spacing of 76mm x 76mm, which must be fitted with a quick release mechanism.

8. 1kg FIRE EXTINGUISHER

A 1Kg Dry Powder Gauge Fire Extinguisher is highly recommended and if fitted, this should be in a tube with a spring top and should be within easy reach of the driver. Old type BCF (green) type extinguishers are not allowed. All tow vehicles, must carry a minimum of a 2kg fire extinguisher dry powder or gas, which must be within easy reach of the driver and mechanics at all times, especially when refueling.

9. COMPETITION STYLE DRIVERS SEAT WITH HEAD RESTRAINT

You must have a Competition type Driving Seat with a head restraint. The seat should occupy its original position where possible and be suitably supported at shoulder height and on both of the sides and back, with a suitable framework or seat stiffener's.

Additional wrap around seat support at shoulder height.

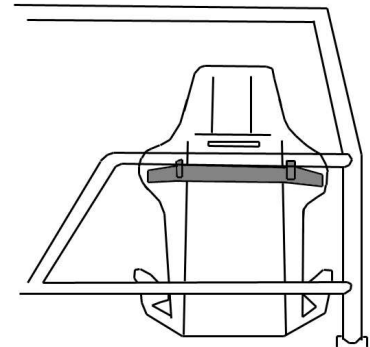

10. SAFETY HARNESS

The lap belt/straps and crotch straps should not pass over the sides of the seat, but through it, in order to wrap and hold the pelvic region over the greatest possible surface

It is mandatory to have a 5 point Safety harness with 3" shoulder straps, the lap & crutch straps can be either 2" or 3" in width.

All seatbelt connection points must be visible and no belts must pass through any firewall.

Following research made by leading safety harness manufacturers, information has been made available with regard to the best way to fit your safety harness; this will further ensure your safety. Please study the diagrams to ensure your safety harness is fitted correctly.

The lap belt crossing should be below the anterior-superior iliac spines (bony part of the hip). Under no circumstances should it be worn over the region of the abdomen.

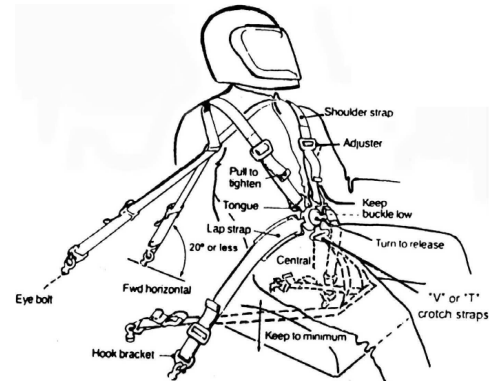

Lap belt/straps **must terminate vertically downwards**, and not forwards or rearwards of the hip joint. Lap straps should terminate symmetrically about the wearer on either side of the seat, about 20" (500mm) apart. The distance between the seating surface and the anchorage point should be kept to a minimum to prevent submarining.

The location of the crotch strap mounting should be to the rear of the driver.

Fig.1 shows the location for the tail straps, which should be horizontal to 20° below horizontal, and as close to the shoulder as is practical for optimum restraint.

Only safety belts comprising of separate shoulder, lap, and sub-straps will be permitted.

The sub-strap must be used at all times, and all belts must connect to the quick release buckle. The abdominal strap fixing point must be on the chassis, roll cage, or floor (for vehicles with no chassis), either side of the driver.

The shoulder straps must be supported at shoulder height. NASCAR type buckles must be fitted with lever on the **right** side of the driver. It is advisable to fit a secondary means of detent to prevent overall sleeves accidentally unhooking the buckle during racing. A small section of tube grip **elasticated** bandage, slid over the hooked buckle, serves the purpose.

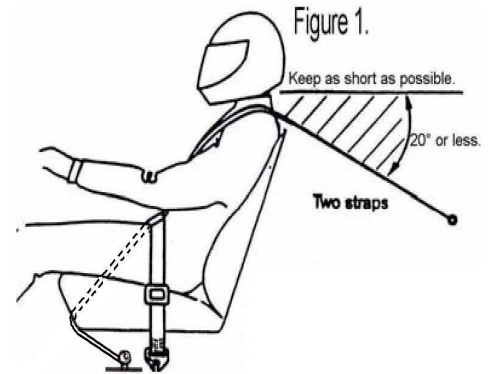

Special attention must be paid to the condition of seat belt fixings once fitted. Information is available, from your Promotion, on the correct procedure to follow when fitting seat belts. *Remember - your life depends on them, and belts, once involved in a severe accident, should be discarded and replaced.*

Over the years, we have had many unnecessary injuries due to badly fitted seats. They frequently occur in Non-contact Formulas, when perhaps a driver believes it is more unlikely that he will be involved in a serious crash, and he also believes that, if he is involved in a collision, the impact on his car will be from the front. However, this is often not the case. It is therefore, imperative that you ensure your seat is really well supported, especially where the shoulder straps go through. You must also ensure that your seat cannot move sideways.

The safety of your seat will be judged by the Scrutineer's and you will only be permitted to race when they are satisfied that you will be as safe as possible in any event.

6. ROLL CAGE

Key: SHS - Square Hollow Section.
RHS – Rectangular Hollow Section.
CHS – Circular Hollow Section.

The roof may be removed to aid welding and fitting of the cage, but it must not be lowered or shortened when refitted. The roll cage must be constructed from either 38mmx38mm or 40mmx40mm SHS or CHS, with a wall thickness of 3 to 3.5mm & it must support both the A & B pillars. The cage must consist of the following minimum ironwork :

1. One front hoop over the A posts.
2. One rear hoop over the B posts.
3. Two cant rail roof bars connecting the A & B hoops, with an additional third central roof bar.
4. A 3mm plate is to be welded on all four sides on top of the roll cage frame above the driver.
5. The roll cage hoop feet must be welded to four 3mm thick plates 100mm square or alternatively welded to the iron work.
6. There must be one front crossbar at dash height.

7. There must be two crossbars behind the driver, one of which must be at shoulder height to support the seat.
8. Any part of the cage coming in to contact with the driver must be padded.

7. STRAIGHT THROUGH IRONS

- a. All cars must consist of two straight through irons made of 50x50x5mm thick SHS iron.
- b. When they sit on top of the chassis you can shorten the cross member bolts so as it sits lower, or you can fit the irons inside of the chassis members. You cannot modify the engine cross member to make it fit. *You must fit a Mk2 cross member when the rails are fitted inside the chassis members.*
- c. The straight through rails must go through the car and step up and over the boot floor.

8. FRONT BUMPER IRONS

1. ***Must be constructed by 50x50 SHS iron, maximum thickness 5mm and consists of a minimum of 6 and maximum of 9 uprights and 2 cross bars top and bottom.***
2. The cross bars may have straight or angled ends.
3. The minimum height of the bumper is 330mm or 13" & the total width is 1726mm or 68"
4. If the straight through irons sit on top of the chassis, the bottom cross bar of the bumper must sit underneath the ends of the straight through irons.
5. If the straight through irons fit inside the chassis then the bottom rail must butt up against the ends of the straight through irons.
6. The front bumper top rail must be a minimum distance of 1092 mm or 43" from the centre of the windscreen apertures lower edge.
7. A piece of 2"x 2" box iron must be fitted on the passenger side of the bumper to protect the wheel. This must go lower down to the floor then angled back up to the bumper (as shown in the rough diagram below).

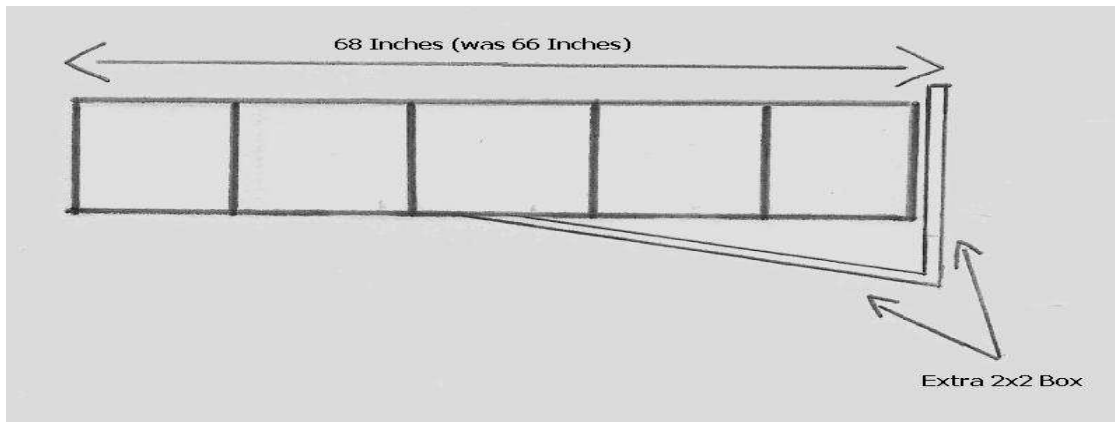

9. REAR BUMPER IRONS

1. ***This must be a single rail of 50x50 maximum 5mm SHS iron & must sit on top of the straight through irons outside the rear of the car. Optional you may make a double rear bumper with height of 6 inches from top edge to bottom edge constructed of 38x38 or 50x50 box iron.***

10. SIDE IRONS

1. They must be constructed the same on both sides of the car, from 38x38mm or 1½ x ½ x 3mm or 4mm thick SHS iron ***this can now be double up side by side by 38x38 but must be same either side or 50x50 box iron but must be cemetrical on both sides.***
2. ***They can go from the front bumper through to the rear wing iron and can be connected to the rear bumper.***

11. NEARSIDE FRONT WHEEL IRONS

1. You may run an extra piece of 50x 25mm or 2"x1" RHS iron, on the outside of the side iron, connected to the front bumper & down to the lower door iron.
2. This extra piece of iron must not go past the "A" pillar. The object of this iron is to help to protect the NSF wheel, with its negative camber. This will be the only iron work (except for the bumpers) to be on the outside of the car.

12. REAR WING IRONS AND REAR WHEEL PROTECTION

1. These must be made of 50x50mm or 2"x2"x5mm thick SHS iron.
2. Rear wheel irons must be 1 ½" X 1 ½" with a maximum thickness of 4mm – these should not be covered in.
3. ***You may use a single leaf spring. All rear wheel protection must match both sides and must not be covered in.***

13. DOOR IRONS

1. ***The top door iron must be constructed of 38x38mm or 50x50mm 3-4mm thick SHS iron.***
2. The bottom door iron must be made out of 50x50mm or 2"x2" by 5mm thick SHS iron.
3. The minimum gap between the top & bottom door irons is 140mm or 5½".
4. The height of the lower door iron must be level with the middle of the front bumper.
5. From the top of the front door seal to the lower door iron, there must be a minimum gap of 190mm or 7½".
6. A 3mm thick steel plate must be welded on the outside of the chicken bars, between the top & bottom drivers door irons. The original panel has to be welded over this.

14. SUSPENSION GENERAL

1. To be fitted as original.
2. No adjustable parts are allowed.
3. All suspension parts must be located on the original mounting points on the chassis & body.
4. Only standard bushes are permitted, solid bushes, competition, Cosworth or XR4 types, are not permitted.
5. On the Anti-roll bar to lower suspension arm location only the original bushes can be used, but the crush tubes can be shortened & an extra washer may be added either side of the bush. N.B. whatever washers are fitted on off-side must be replicated on the near-side, so that they are identical.

15. OSF SUSPENSION

1. Must stay completely standard, except for the crush tubes.

16. NSF SUSPENSION

1. Negative camber is permitted on the NSF wheel but it cannot be adjustable. You may add a piece of metal up to a maximum of 75mm or 3", between the anti-roll bar fixing and the outer ball joint only, to achieve the desired Camber angle.

17. REAR SUSPENSION

1. Must remain as standard.
2. Only standard bushes are permitted, solid bushes, competition, Cosworth or XR4 types, are not permitted.
3. You may bring an extra support down from the iron work to the back axle to hold the axle in position.

When repairs are carried out they must be within the following tolerances:

Rear Camber angle. Minimum 0° Maximum 3° Negative.

Example: If you have 3° Neg on the NSR you must have 3° Neg on the OSR.

Rear wheel alignment or Toe: $0^{\circ} \pm \frac{1}{2}^{\circ}$.
Shimming of the rear hubs is permitted to achieve the tolerances given.

18. THE STEERING

1. Power steering racks can be replaced with manual ones from the Sierra range.
2. No quick racks can be used
3. Power steering pumps can be removed.
4. A quick release steering wheel is permitted.

19. THE SPRINGS

1. Springs are free and you can fit the 2¼" diameter type, by relieving the ring around the insert to allow fitting. This is the only modification allowed.
2. Only one spring is allowed per corner.
3. The rear chassis platform around the raised centre part may be cut back level with the chassis, to leave a hole to accommodate 2¼" springs.

20. RIDE HEIGHT & WEIGHT

1. This is measured without the driver, from the bottom of the sill (not the rebate lip) to the ground, and this ride height measurement must be no lower than 178mm or 7".
2. Spacers may be used to adjust the ride height to attain the setting.
3. Minimum weight for car is 1150KG; maximum weight for car is 1250kg. There is also a maximum of 52% inside (drivers' side) weight.

21. SHOCK ABSORBERS

1. The only units allowed are the standard 2litre replacement units.
Part Numbers as follows:

Monroe	Front	11077	Rear	R2644
Kayba	Front	633832/633067	Rear	441048

Note. Gabrielle Shock-absorbers are not permitted. (Fr 35805 Rr 42537)

2. You are permitted to remove the mounting bracket at the bottom of the casing to allow for height adjustment.

22. WHEEL RIMS

1. ***The standard 13" steel wheel with inset rims are permitted, with a maximum width of 6".***

23. TYRES

1. Tyres must be of the following:
2. Kingpin Pacers (no soft road compounds)
3. Colway Remoulds (with the Spedeworth marking) 175/70R13
4. Yokohama AA01 A/Drive T rated 175/70-13.
5. Tyre buffing is permitted.
6. Tyre softner is not permitted.
7. Tyre gaiters are permitted
8. Mud & Snow/Alpine versions are not permitted.
9. ***We are looking at different types of budget tyres for 2010 season. (To be no dearer retail price than £25 inc VAT and available from most tyre dealers).***

24. REAR AXLE & FINAL DRIVE

1. **You can only use the following final drive ratio's 3.9:2 or 3.6:2 out of a Sierra. (No Granada diffs permitted).**
2. You must lock the differential by welding only.
3. A rear axle support may be fitted from the internal iron work but the axle must remain in its original position.

25. GEARBOX & PROPELLER SHAFT.

1. Only the 5 speed 2 litre Sierra box is to be used. (No P100 boxes)
2. The original gearbox mounts must be used, but may be modified.
3. A one piece propshaft may be used instead of the two piece one.
4. The rotorflex (doughnut) coupling can be replaced by a universal joint.

26. ENGINE

1. The only Engine permitted is the 2 litre Pinto 1993cc with a Camshaft supplied by Spedeworth.
2. Cam & springs are to be supplied by Spedeworth at a cost of £150.
3. All engines are to be standard, with the exceptions detailed below.
4. The sump may be baffled.
5. A secondary fixing is required on the oil filter.
6. The Sierra 2.0 flywheel may be skimmed to a minimum weight of 7.5kg or 16lb 10oz, by removing material from its back face. Flywheel maybe doweled.
7. No additional holes or slots are to be machined into the flywheel
8. The cylinder block can only be bored out to 1mm maximum.
9. The block face can be surface ground but the pistons must not protrude above the block face.
10. Any 2 litre cylinder head can be used but the minimum head thickness is 93.5mm.
11. No machining is allowed to the spring seats, the valves or the ports
12. Valve timing is pre-set so standard pulleys must be used.
13. Valves must be as standard fitment.
14. No Verniers, offset key ways or pin wheels are permitted.
15. Rocker fingers must be of the standard type **or standard replacement, (from most motor factors).**
16. Extended ball studs may be used.
17. The engine must be upright and be on the centre line of the car.
18. The engine should be in its original position and this will be checked by measuring from the centre of the windscreen to the back of the Camshaft pulley.
The distance is minimum 28" inches.
19. The engine mountings maybe modified off the block and may now mount to the straight throughs.

27. ENGINE SEALING

Spedeworth: We may at any time require your engine or other parts to be sealed. This may or may not mean your engine / parts will automatically be stripped or checked. It could be that we wish to monitor your performance or seek clarification on an item. It is normal to strip engines at all major championships unless they run consecutively in which case by agreement with Spedeworth, stripping may be postponed.

Driver: Drivers wishing to have their engines sealed may do so. It will require two people (one may be an official, the other a Scrutineer) to be present at the final stages of a build & it will incur a charge based on the time & distance travelled. If this option is taken at a major championship your engine will not require stripping unless seals have been broken. Seals can only be removed by Spedeworth officials & if they are removed without permission the engine/ parts will be deemed to be illegal & the Driver suspended pending a Board of Control meeting. If any engine/ parts are sealed because Championship events are within a period, which may exclude that Driver due to a rebuild, the Driver with Spedeworth's agreement, postpone stripping for three meetings.

It is the Drivers responsibility to make provision for the sealing of the engine by drilling 1.5mm sealing holes in the following bolts / nuts & marked with red paint for identification purposes:

Either side of the Sump

Two Head bolts, if not covered wholly by a rocker / cam cover.

Two Inlet manifold bolts
Two Rocker / Cam cover bolts
The Bell housing
The Carburettor body and the mounting bolts / nuts.

28. OIL CATCH TANK.

1. A 0.5 litre oil catch tank must be fitted in the engine bay.
2. The tank must have a minimum of 2 breather pipes connected to it: one from the rocker box & one from the crankcase.
3. Ineffective tanks during racing or practice will mean the car being withdrawn from the event.

29. IGNITION SYSTEM - DISTRIBUTOR.

1. You can only use the electronic distributor made by either Bosch or Motorcraft.
2. The vacuum unit may be removed.
3. The mechanical advance maybe altered.

30. CARBURETTOR & INLET MANIFOLD.

1. This must be the twin venturi Weber 32/36 DGVA with a maximum sized chokes of 26mm and 27mm. No polishing or re-profiling is allowed.
2. The standard inlet manifold must be used with its insulating block & two gaskets..
3. The cold starting Choke Butterflies may be removed.
4. You are allowed to change jets.
5. You cannot solder, blank off or drill any holes to modify the Carburettor.
6. A secondary fixing is required on the Carburettor fuel inlet pipe.

31. FUEL SYSTEM.

1. Fuel tanks must be metal or FIA approved & fitted inside the rear boot area, but not below the chassis rails and must be positioned in the centre line of the car from side to side.
2. A complete fire wall must cover the tank and electric fuel pump.
3. You cannot enclose the rear boot area from the seat to the rear window aperture.
4. The tank must have a maximum capacity of 18 litres.
5. Fuel caps must be of a metal screw type, no push fit types are allowed
6. The tank must have a positive means of fixing.
7. The fuel outlet, must be from the top of the tank.
8. Fuel regulators are allowed.
9. An electric fuel pump can replace the mechanically one.
10. All fuel lines must be inside the car and be metal or metal covered.
11. A fuel shut off tap must be within easy reach of the driver.
12. A breather pipe must be fitted which should incorporate a one – way valve, with the pipe terminating below the tank so as to prevent spillage if inverted.
13. The tank should not be below the chassis rails so where a floor exists, four 50mm dia holes should be drilled for drainage purposes.
14. Only roadside fuel can be used. No additives are allowed.

All Oval Racing Formulae

Permitted fuel specification from 1st January 2008 (this specification supersedes all previous specs).

1. All cars must only use fuel from roadside pumps as defined below.
Petrol (Motor Gasoline of the type on sale to the general public from roadside filling stations) BS 4040 (Leaded) Subject to a valid permit for use. LRG (Unleaded), BS EN 228 (Unleaded), BS7800 (Super Unleaded).
2. Petrol is a product refined from crude oil that contains a large number of identifiable compounds that can typically be 250 in number. These compounds can be identified and compared to the available petrol from major oil companies and suppliers.

3. Unless otherwise stated, or the distinction is made between leaded and unleaded petrol, major gasoline fuel shall meet the following; Acceptance levels for Octane numbers will be determined at 95% confidence level. Only additives to this motor gasoline fuel solely for the purpose of lead replacement are allowed.
4. Lead Replacement Gasoline, LRG, also known as LRP. Only additives from Sodium, Phosphorous, Potassium, or Manganese according to manufacturers recommendations are allowed. Note; Manganese can enhance octane values in any petrol. Under no circumstances will values in excess of 0.005 grams/litre be permitted.
Lead in excess of EU directive 98/70EC requirements is illegal.
5. We reserve the right to amend the detail of the above specification to reflect any change occurring in the quality of the fuel on sale to the general public at any time.

Roadside fuel consistency when testing fuel samples.

	BS EN 228	BS 7800	BS 4040	LRG/LRP	Test Standard
Motor Oct No (max)	89.0	89.0	89.0	89.0	ASTM D2700/86
Mon (min)	85.0	86.0	86.0	86.0	ASTM D2700/86
Research Oct No (max)	100.0	100.0	100.0	100.0	ASTM D2699/86
Ron (min)	95.0	97.0	97.0	97.0	ASTM D2699/86
Lead (max)	0.005	0.005	0.15		ASTM D3341 / IP362
Lead (min)	ASTM D3237	ASTM D3237		0.005	ASTM D3237 / D3341 / IP362
Density @ 15°	0.720 - 0.775	0.720 - 0.775	0.720 - 0.775	0.720 - 0.775	ASTM D1298/ D4052
Oxygen % max	2.7% w/w	2.7% w/w	2.7% w/w	2.7% w/w	Elemental
Nitrogen % max	0.1% w/w	0.1% w/w	0.1% w/w	0.1% w/w	ASTM D4629/ IP379
Benzene % max	1.0% v/v	1.0% v/v	1.0% v/v	1.0% v/v	EN238
Sulphur	150mg/kg	150mg/kg	150mg/kg	150mg/kg	EN ISO 14596 / ASTM D2622
Olefins*	18% v/v	18% v/v	18% v/v	18% v/v	ASTM D1319
Aromatics*	42% v/v	42% v/v	42% v/v	42% v/v	ASTM D1319

* Olefins and Aromatics values are expressed as a percentage of total fuel.

32. EXHAUST SYSTEM

1. The exhaust manifold must be the standard 2 litre one with twin downpipes.
2. The front down pipe must be standard even down to the bolt together flange at the bottom, which can be welded to next section of exhaust.
3. You must use an AX891 silencer.
4. There must be 254mm or 10" of tail pipe on the end of the silencer facing rearwards.
5. If your exhaust becomes ineffective in the last 5 laps of a race you **must** pull off, as you will be automatically removed from any results.

33. BATTERIES & THE ELECTRICAL SYSTEM.

1. The Battery(ies) must be securely fixed & covered with rot proof material if they are not of the sealed type.
2. Battery(ies) may be in a battery box, and the battery must be positioned in the middle, of where the rear seat was originally fitted but forward of the axle centre line.
3. A battery master switch must be fitted in the rear left-hand window and clearly marked "ON- OFF" or have an electrical danger decal.
4. When an electric fuel pump is used, a cut off switch must be positioned within easy reach of the driver.
5. A self-starter motor must be fitted & working at all times.
6. A 24volt system may be used.

34. INTERIOR MIRROR.

1. *A rear view mirror is only permitted for white and yellow grade drivers, (unbreakable mirror only).*

35. BODYWORK

1. *You may replace the lower section of body panel with 1.5mm steel plate no higher than the door handle swage line and no lower than the top of the original sill but the car must keep its original silhouette.*
2. The engine should not be visible between the lower edge of the front window aperture & the back edge of the bonnet for fire safety reasons.
3. The bonnet should be the standard sized panel.
4. Front wings below the ironwork may be removed in front of the wheel.

36. PAINTWORK.

1. The external appearance of the car must look professional at all times, drivers of scruffy looking cars will be told to improve their appearance & may not be allowed to race.
2. A maximum of two cars may be painted in team colours or painted to look similar, unless it is required by the Promoter for a particular team event.
3. 100% of the roof must be painted in the correct roof grading unless you are a Superstar or a current Championship holder, when the roof must be painted accordingly.
4. Sign writing must be professional and be approved by the Promoter.

37. SUN VISOR.

1. A Sun visor 165mm or 6" in depth must be fitted with your name written upon it.

38. FIN PLATES & ROOF NUMBER.

1. Fin plates must be fitted above the roof line but it should not be larger than 305mm or 12" by 559mm or 22" wide.
2. Fin plate numbers must be 229mm or 9" high by 38mm or 1½" in width, black numbers on a white background. Please ensure they are correct.
3. The racing number can be painted on the roof, but please be aware that grading colours must be 100% of the roof.

39. DOOR NUMBERS

1. The drivers racing number must appear on both sides of the car. The numbers should be 300mm or 12" high x 50mm or 2" wide, on a contrasting background, which must extend a minimum of 50mm or 2" beyond the numbers.

40. SPECIFICATION AND RULE CHANGES.

The Promotion may at any time make amendments to the Specifications for the following reasons:

- In the interests of Safety
- Reduce costs for the driver
- In areas that are detrimental to the future of the formula
- If an unnecessary advantage has been deemed.

Current registered drivers will be notified automatically of any changes.

41. ROOF GRADING

1. All roof grade champions must start at the rear of the Grid, unless told otherwise by an official.
2. If you win a race at a meeting; you will start the remaining races from the rear of your grade. Should you win another race at the same meeting – you will be automatically upgraded.
3. Drivers are reminded that they should line up in points order on the grid with the engine switched off. Drivers with incorrectly painted roofs after the points chart has been issued will have to start at the rear of the grid.

Grid Line up / Roof Order:

- White
- Yellow
- Blue
- Red
- Superstar (Red, White & Blue Stripes)
- Supreme Champion (Red & White checkers)
- Silver Roof - Points Champion
- White with Red Cross – English Champion

42. SCRUTINEERING OF NEW CARS

All new cars must be Scrutineered prior to its first meeting. Arrangements must be made with Spedeworth to bring the car along to a Stadium on the day of an event and then your car will be Scrutineered